

**CONLUX**

Multi-select Multi-price 3Tube Coin Changer

**USLX-1, USLX-2**

**USLX-9** Series

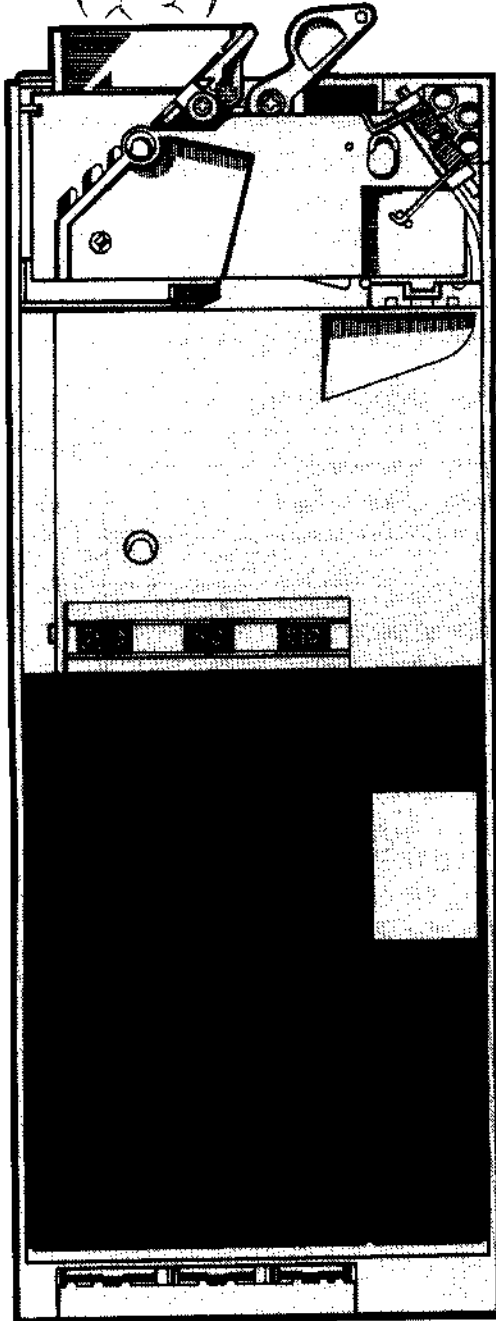

**Service Manual**

**CONLUX USA CORPORATION**

## TABLE OF CONTENTS

	<b>Page</b>
<b>1 Outline</b> .....	3
Warranty .....	3
<b>2 General Specifications</b> .....	4
<b>3 Detailed Specifications</b> .....	4
<b>4 Model Number</b> .....	5
<b>5 Handling and Installation</b> .....	6
5-1 Handling Instructions .....	6
5-2 Names of the Parts and their Functions .....	6
5-3 Installation Procedure .....	7
5-4 System Switch SW1 Setting .....	7
5-5 Loading the Change Tubes .....	7
5-6 Vend Test .....	8
<b>6 Construction and Description</b> .....	8
6-1 Description of Parts .....	8
6-2 Coin Paths .....	9
6-3 Discrimination Method .....	10-11
6-4 Operation of Switches, Sensors and Parts .....	12-13
6-5 Payout System .....	14
6-6 Input and Output Configuration .....	15
<b>7 Wiring Diagram</b> .....	16
7-1 USLX-001 Wiring Diagram .....	16
7-2 USLX-002 Wiring Diagram .....	17
7-3 USLX-004 Wiring Diagram .....	18
<b>8 Preventive Maintenance</b> .....	19
<b>9 Disassembly and Assembly Procedure</b> .....	20-24
<b>10 Parts Diagram and List</b> .....	25-28
10-1 Changer (front side) .....	25-26
10-2 Changer (rear side) .....	27-28
<b>11 External View and Dimensions</b> .....	29

**NOTE: TECHNICAL SUPPLEMENT AVAILABLE UPON REQUEST**

## 1. OUTLINE

- The USLX-series (M.S.M.P.) Multi-Select-Multi-Price, serial interface electronic coin changers, accept: U.S. 5¢, 10¢, 25¢, and \$1 coins.
- Change is paid out from each of the changers three tubes, according to payout signals from the machine controller.
- All USLX-series coin changers have built-in water protection, draining off water to the side or front, preventing serious damage to vital parts of the changers.

### Warranty

CONLUX USA CORPORATION warrants all new equipment sold by it to be free from defective material and workmanship. Conlux will repair or replace (at its option) any part of the equipment which proves to be defective in materials or workmanship within a period of twelve (12) months from the date of original sale. In addition, printed circuit board assemblies will be warranted for a period of thirty-six (36) months from the date of sale of the equipment containing the printed circuit board.

Other conditions applying to this warranty are as follows:

1. This warranty will not apply to any equipment which has been, in Conlux's opinion, subject to: accident, abuse, misuse, neglect, improper installation, or improper maintenance or repair by unauthorized service personnel.
2. Conlux will not be responsible for any expense incurred by the purchaser incidental to the repair or replacement of equipment covered by this warranty.
3. Freight charges to send the equipment to Conlux or Conlux appointed Independent Authorized Service Center for warranty service will be the responsibility of the purchaser.
4. THIS WARRANTY IS IN LIEU OF ALL OTHER WARRANTIES ORAL OR WRITTEN, EXPRESSED OR IMPLIED, INCLUDING WITHOUT LIMITATION, WARRANTIES OF MERCHANTABILITY, WARRANTIES OF FITNESS OF PURPOSE, AND ALL OTHER OBLIGATIONS OR LIABILITIES OF CONLUX. CONLUX NEITHER ASSUMES NOR AUTHORIZES ANY PERSON TO ASSUME FOR IT, ANY OTHER OBLIGATION OR LIABILITY IN CONNECTION WITH THIS WARRANTY POLICY.
5. LIABILITY TO CONLUX USA AND ITS APPOINTED INDEPENDENT AUTHORIZED SERVICE CENTER IS LIMITED TO THE REPAIR OR REPLACEMENT, AT THEIR OPTION, OF DEFECTIVE PARTS AND DOES NOT INCLUDE INCIDENTAL AND CONSEQUENTIAL DAMAGES.

**2. GENERAL SPECIFICATIONS**

Specifications and design are subject to change without notice.

Items	USLX-001 Series	USLX-002/004 Series	
Coins Accepted	U.S. 5¢, 10¢, 25¢, \$1 coins		
Coins Paid Out	5¢, 10¢, 25¢ coins (automatic replenishment)		
Coin Tube Capacity	5¢ coins ..... approx. 74 ±3 coins 10¢ coins ..... approx. 103 ±3 coins 25¢ coins ..... approx. 77 ±3 coins		
Change Payout	DC Solenoid (5¢, 10¢, 25¢ tubes)		
Power Supply	DC 5 V,DC117V±10%(Full-wave rectified)	DC 5 V,DC24V±10%(Full-wave rectified)	
Insulation Resistance	20MΩ or greater		
Operating Temperature Range	+5°F ~ 140°F		
Rated Power Consumption	0.2A (Wait State) 2.2A (Operate State)		
Weight	5 Lbs.		
Power Harness	12 Pin	12 Pin	15 Pin

**3. DETAILED SPECIFICATIONS****1 Payout System**

1.1 Types of Change 5¢, 10¢, 25¢ coins (automatic replenishment)

1.2 Payout System DC Solenoid

1.3 Coin Tube Capacity

5¢ coins .... approx. 74 ±3 coins

10¢ coins .... approx. 103 ±3 coins

25¢ coins .... approx. 77 ±3 coins

1.4 Change Detection

Coins are detected by sensors in the payout tubes. And by the empty counter, counting coins inserted through the discriminator section of the coin changer. Routed into the tubes.

An empty, out of change condition is assumed when:

1.4.1 Out of 5¢ Coins.

When the 5¢ empty sensor detects no coins and the empty quantity counter shows less than 20 coins.

1.4.2 Out of 10¢ Coins.

When the 10¢ empty sensor detects no coins and the empty quantity counter shows less than 10 coins.

1.4.3 Out of 25¢ Coins.

When the 25¢ empty sensor detects no coins and the empty quantity counter shows less than 8 coins.

**2 Coin Rejection**

In the following cases, inserted coins are rejected.

(1) When the power is off (power failure).

(2) When the coin accept signal is cut off.

(3) When the coins are being paid out.

**4. MODEL NUMBER**

**4. MODEL NUMBER**

The product model name is described in the table below.

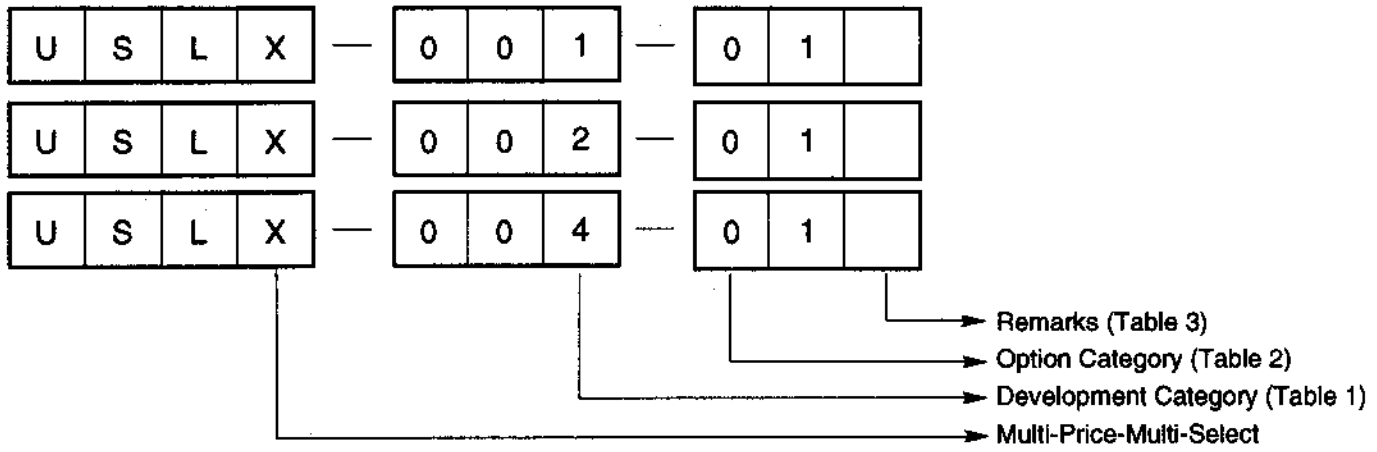

Table 1 Development category

Model Number	Voltage	Harness Plug
1	117V DC	12-pin Connector
2	24V DC	12-pin Connector
4	24V DC	15-pin Connector

Table 2 Options

	Drain Tube	Switch Cover	Drain Spout	Rubber Elbow
0	✓	✓	✓	✓

Table 3 Remarks

Letter	Drain Spout (side)	Drain Spout (2) (front)
L	Installed	Option
F	Option	Installed

## 5. HANDLING AND INSTALLATION

### 5-1 Handling Instructions

Do not carry the coin changer by the harness.

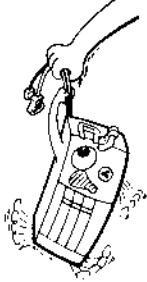

Do not drop the coin changer.

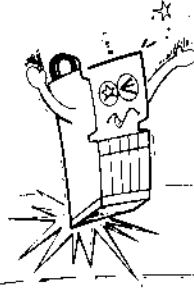

Handle the gate assembly gently when opening and closing by hand.

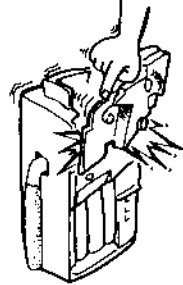

Store the coin changer in a dry, clean location.



### 5-2 Names of the Parts and their Functions

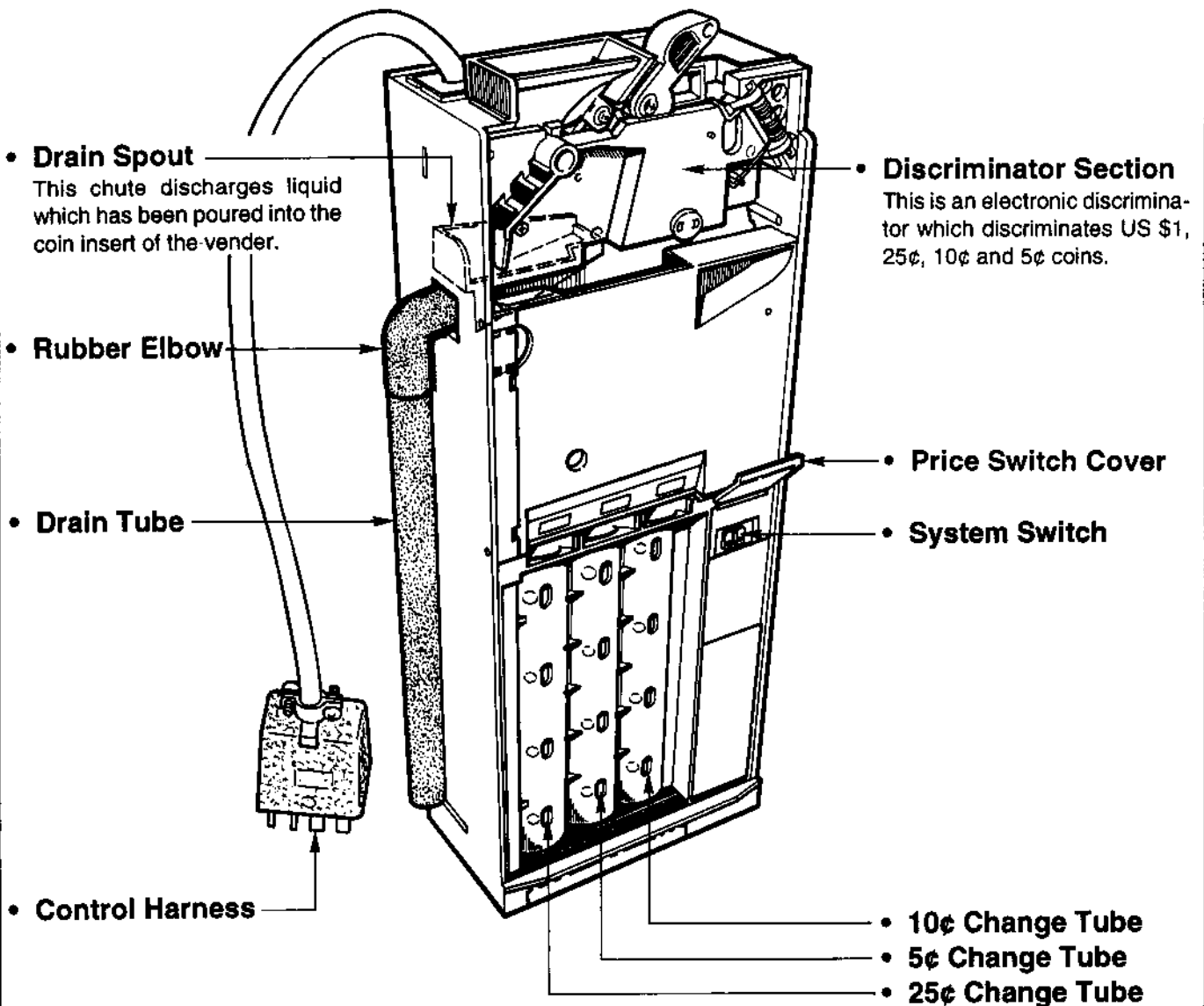

## 5-3 Installation Procedure

1. Attach the changer by aligning the key holes with the mounting screws on the vending machine, and fasten securely.

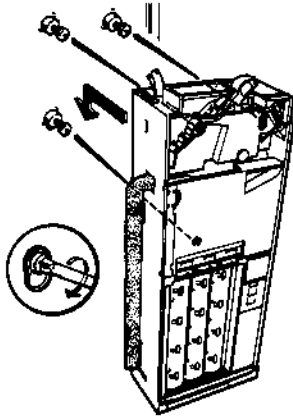

**NOTE:**  
THE DISCRIMINATOR CAN  
NOT BE REMOVED FROM  
THIS COIN CHANGER.

2. Connect the 12 pin plug (USLX-001/002) or 15 pin plug (USLX-004) into the vending machine socket.



**CAUTION: DO NOT PLUG OR UNPLUG COIN CHANGER WITH POWER ON.**

## 5-4 System Switch SW1 (Double DIP Switch)

\$1 coins acceptance and 25¢ tube capacity are selected by the system switch.

1. Setting switch 1 of the system switch selects \$1 coin acceptance or rejection.

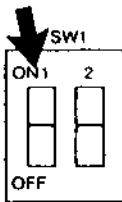

System Switch 1	Content
ON	\$1 Coin Accepted
OFF	\$1 Coin Rejected

2. Setting switch 2 of the system switch selects 25¢ change tube capacity HIGH or LOW.

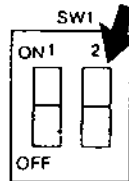

System Switch 2	Content
ON	25¢ HIGH
OFF	25¢ LOW

- ① **HIGH setting :**

25¢ coins are routed to the cashbox when the change tube is full.

- ② **LOW setting :**

25¢ coins are routed to the cashbox when the change tube contains 12 coins.

## 5-5 Loading the Change Tubes

- Loading 5¢, 10¢ and 25¢ Coins

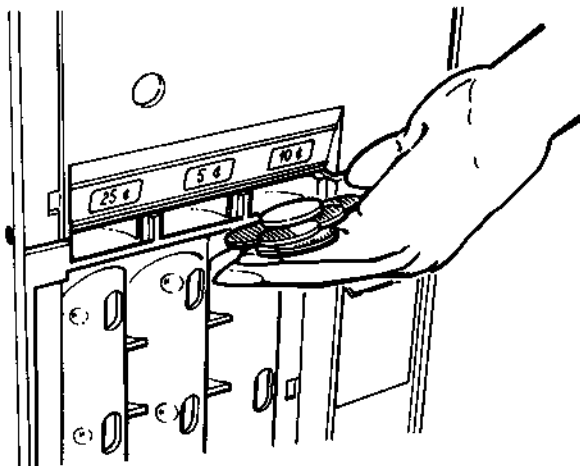

Quarters  
25¢



Nickels  
5¢



Dimes  
10¢



**Note:**

- ① If a coin drops in and stands on end, correct it.
- ② Be careful not to load bent coins.

### 5-6 Vend Test

- ① Set the system switch SW1.
  - Select acceptance or rejection of 1\$ coins with the DIP switch No. 1.  
ON → Acceptance OFF → Rejection
  - Select the coin capacity of the 25¢ tube HIGH or LOW with the DIP switch No. 2.  
OFF → Inserted 25¢ coins routed to the cash box when the EMPTY switch is in the "change present" status ( $11 \pm 3$  coins).  
ON → Inserted 25¢ coins routed to the 25¢ tube until detection by the overflow switch.
- ② Connect the 12 pin Plug (USLX-001/002) or the 15 pin Plug (USLX-004) into the socket of the vending machine.
- ③ Place coins into the respective change tubes.  
5¢ tube → 20 coins, 10¢ tube → 20 coins, 25¢ tube → 15 coins.
- ④ Insert 5¢ coins, 10¢ coins, and 25¢ coins in various combinations through the coin insert slot of the vending machine, until the vend price is reached. Then execute vending operation and confirm correct vending.
- ⑤ Insert a 25¢ coin. Confirm that the 25¢ coin is routed to the cash box when the DIP switch No. 2 is OFF. Confirm that it is routed to the 25¢ tube when the switch is ON!  
Next, operate the RETURN lever and confirm that the 25¢ coin is returned.
- ⑥ Execute the inventory operation from the vending machine controller, for each change tube.  
Then payout all the change.

## 6. CONSTRUCTION AND DESCRIPTION

### 6-1 Description of Parts

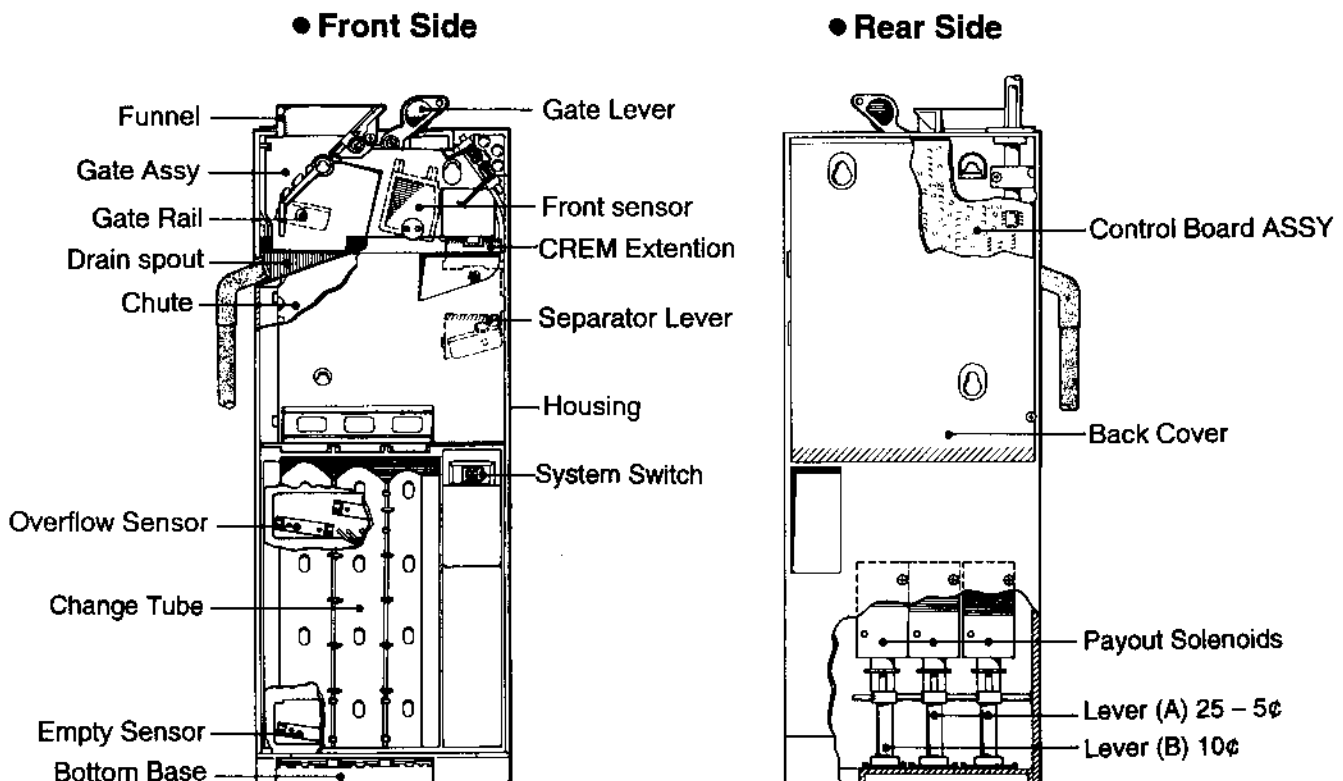



## 6-2 Coin Paths

Coins which are accepted and pass the credit sensor are guided to the change tubes or cash box. If an overflow sensor detects coins in a tube, the additional inserted coins are guided to the cash box. The change paid out by payout solenoids, defective coins (including slugs), etc. are returned to the coin return cup of the vending machine.

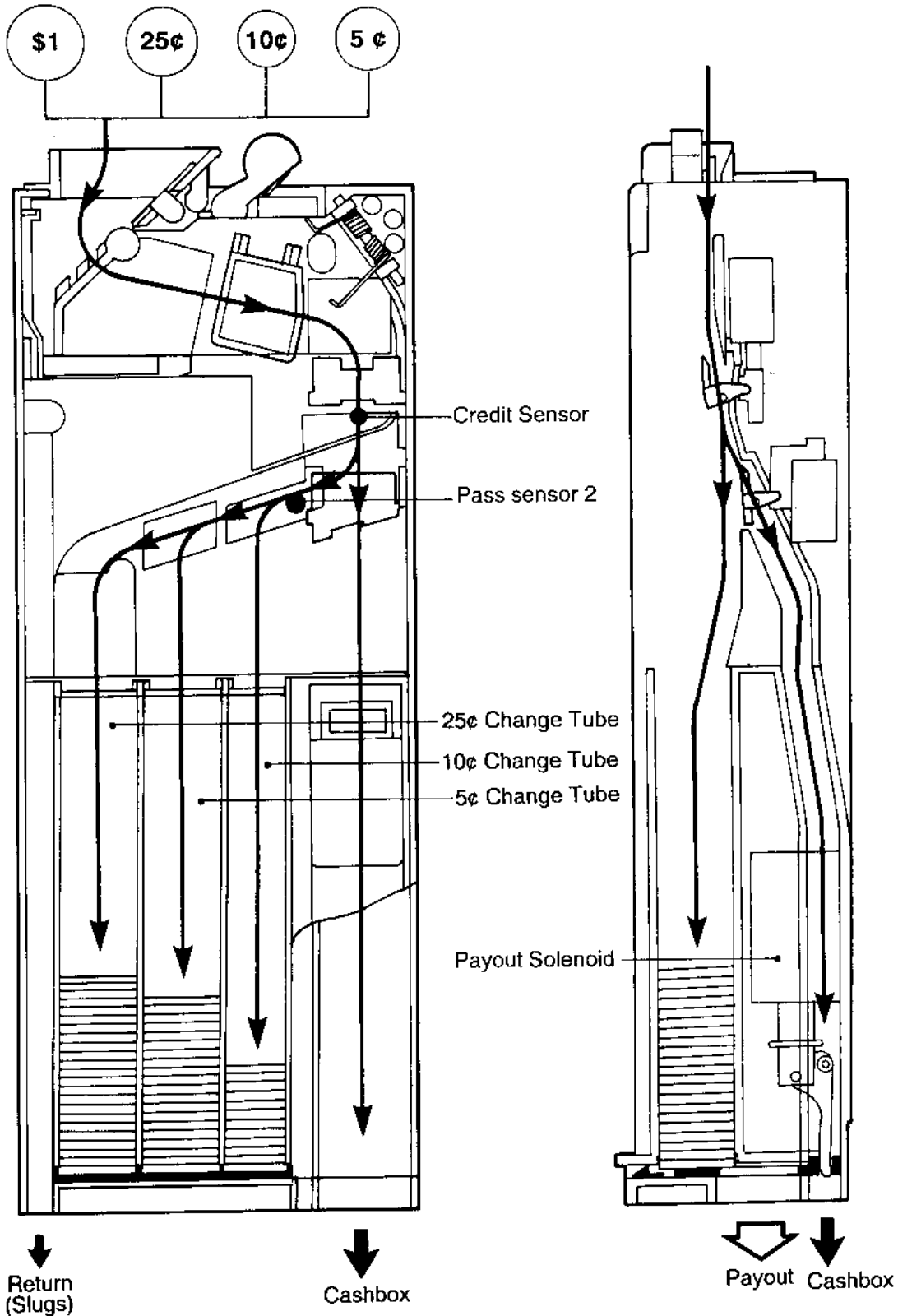

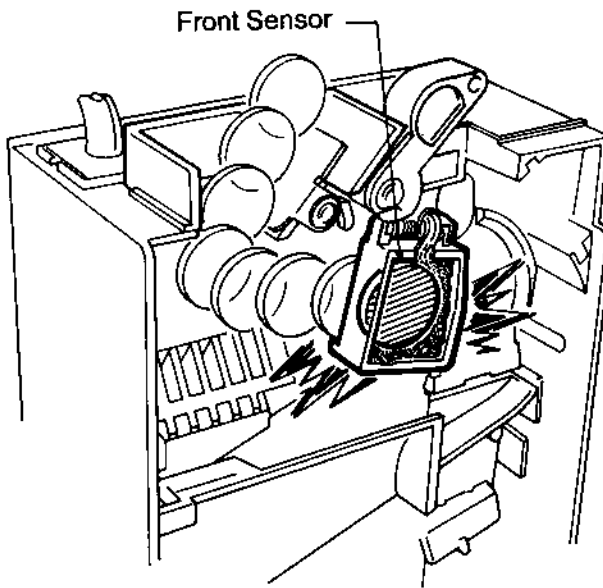
**6. CONSTRUCTION AND DESCRIPTION****6-3 Discrimination Method****6-3-1 Discrimination by Metal Content and External Shape (Diameter)**

When coins pass between the front sensors, the metal content and diameter of the coins are checked and compared with the preset reference values of the control board. A coin is judged to be genuine only when these values match.

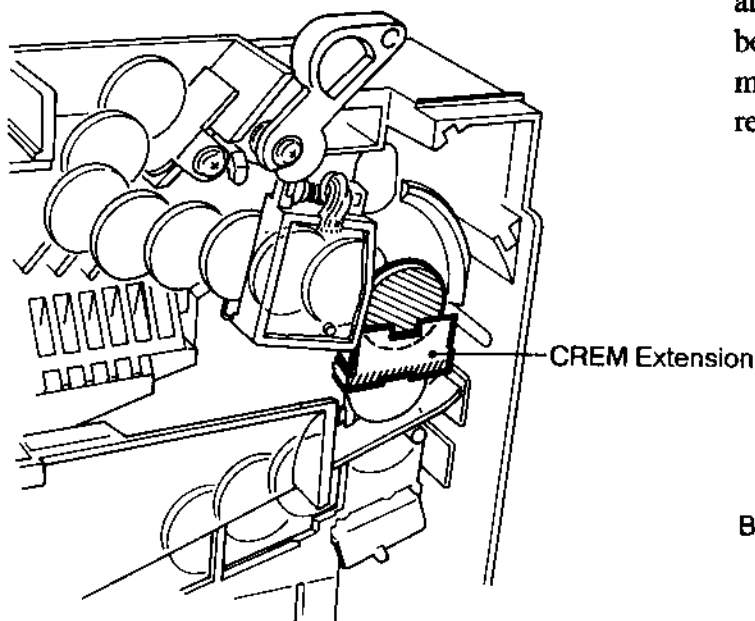
**6-3-2 CREM Solenoid and CREM Extension**

If a coin is judged to be good, the CREM solenoid operates, the CREM extension opens and the coin is received. If a coin is judged to be bad (defective), the CREM extension remains closed and the coin is guided to the return chute.

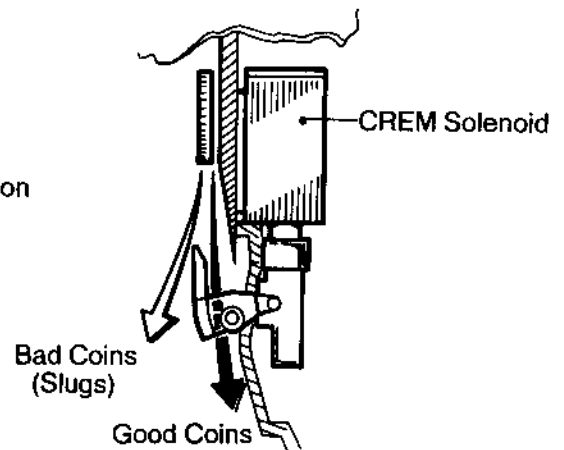

### 6-3-3 Separator Solenoid and Lever

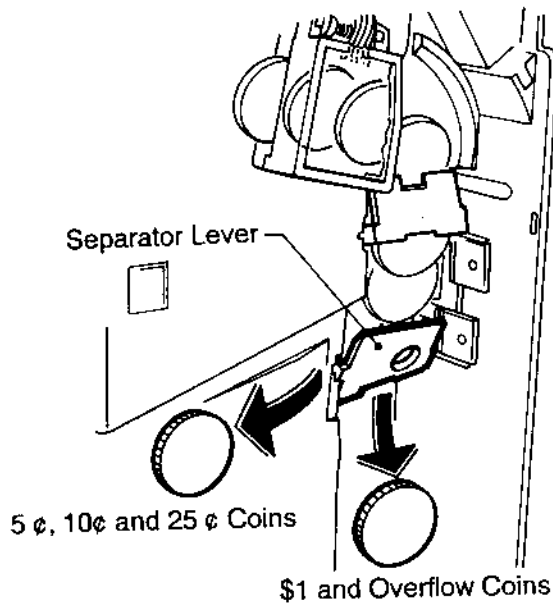

When 5¢, 10¢ and 25¢ coins are accepted, the separator solenoid operates and a chute rail guides the 5¢, 10¢ and 25¢ coins into their respective coin tubes. \$1 and overflow coins drop to the cash box in the vending machine.

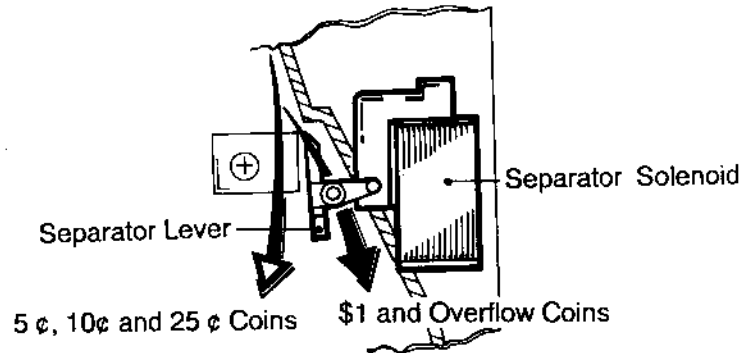

### 6-3-4 Separation of 5¢, 10¢ and 25¢ coins by the Separator Chute

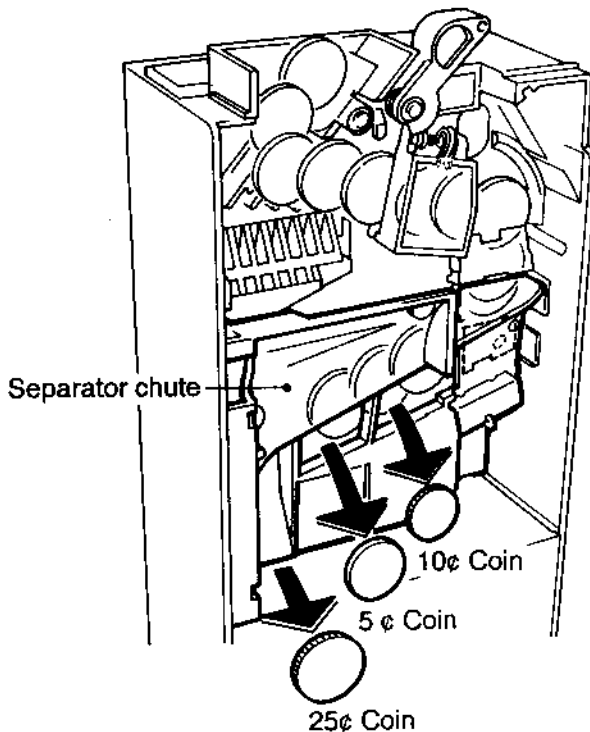

25¢ coins roll along the rail in the separator chute and are guided to the 25¢ coin tube. 5¢ and 10¢ coins roll along the same rail in the separator chute but drop off along the way and are guided into their coin tubes.

## 6. CONSTRUCTION AND DESCRIPTION

## 6-4 Operation of Switches, Sensors and Parts

## 6-4-1 Gate Lever Assembly and Related Parts

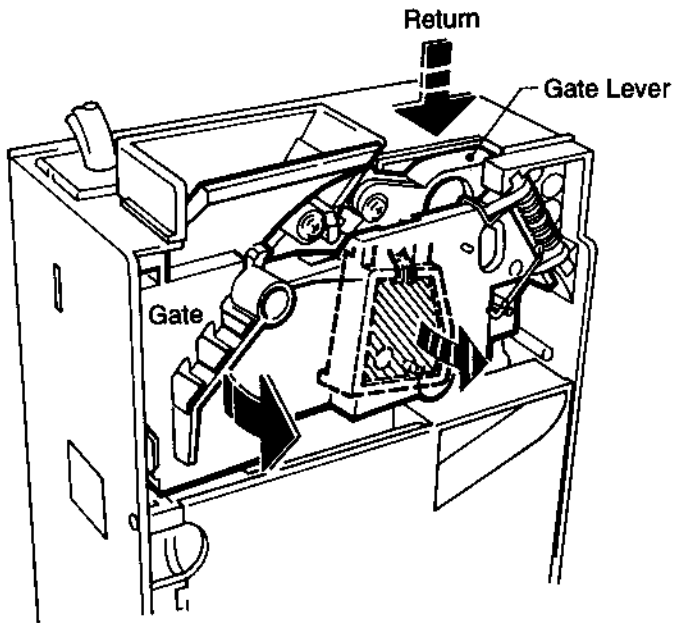

When the return lever on the vending machine is operated, it pushes the gate lever down and the gate opens.

If there are any defective coins, etc. stopped behind the gate, this operation causes them to be guided into the coin return chute. In addition, the movement of the front sensor causes the cancel signal to be sent. (escrow)

- The movement of the Front sensor

Normal Position    Gate Lever Depressed

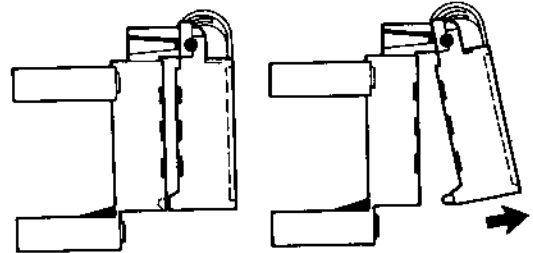

Cancel Signal OFF

Cancel Signal ON  
(Escrow)

## 6-4-2 Anti Stringing Hook

The hook of the housing prevents stringing!

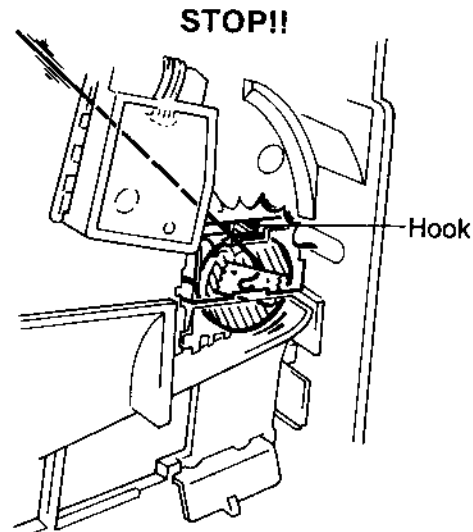
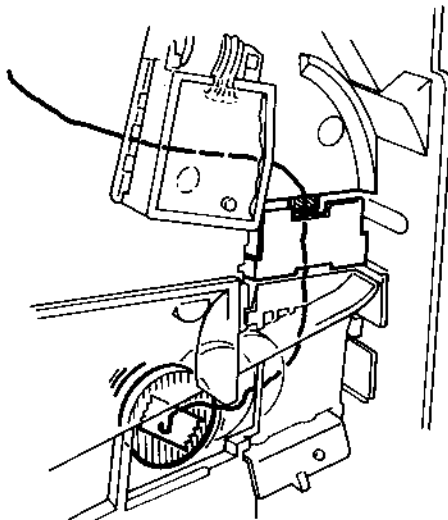

## 6-4-3 Credit Sensor

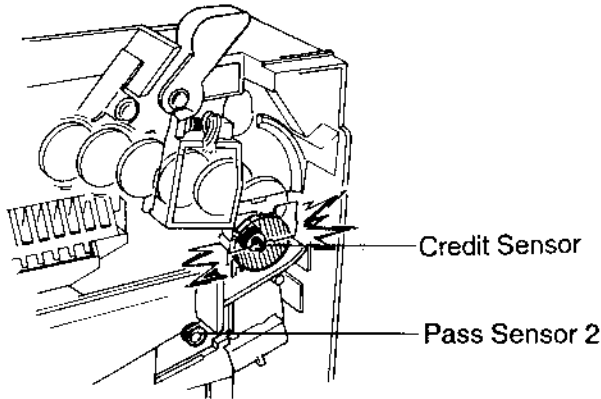

- Credit sensor

When a coin is determined to be genuine by the front sensor, it will be guided past the credit sensor and its value will be accumulated in the memory of the control board.

- Pass sensor

The pass sensor verifies coins routed to the tubes and reports to the controller.

## 6-4-4 Overflow and Empty Sensors

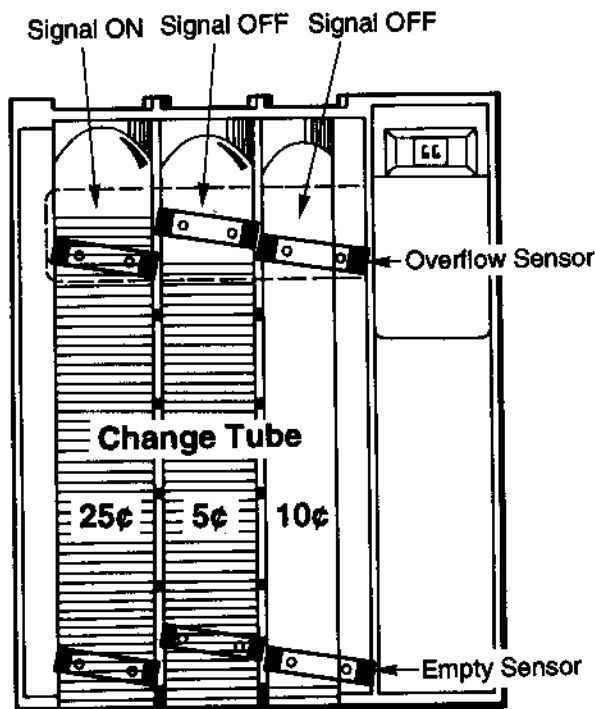

- Overflow sensor

This sensor detects the full level of coins in the change tube.

If the tubes are full, the overflow signal is sent and coins are guided to the cash box.

- Empty sensor

This sensor detects the presence of coins in the change tube.

The coin changer will determine the tubes to be empty when the coins are below the sensor levels.

5¢ coin change tube: 15 ±3 coins  
10¢ coin change tube: 15 ±3 coins  
25¢ coin change tube: 11 ±3 coins

## 6. CONSTRUCTION AND DESCRIPTION

## 6-5 Payout System

The 3 payout solenoids are operated by the control board.

Voltage supplied to a payout solenoid produces an electromagnetic force which pulls the solenoid plunger inside the solenoid.

This movement compresses a spring and causes the lever (attached to the plunger) to push the change slide outward, underneath the change tube removing a coin from the tube.

The voltage is then removed from the payout solenoid and the compressed spring forces the payout slide back to its original position and the coin is dropped from the payout slide through a hole in the bottom base.

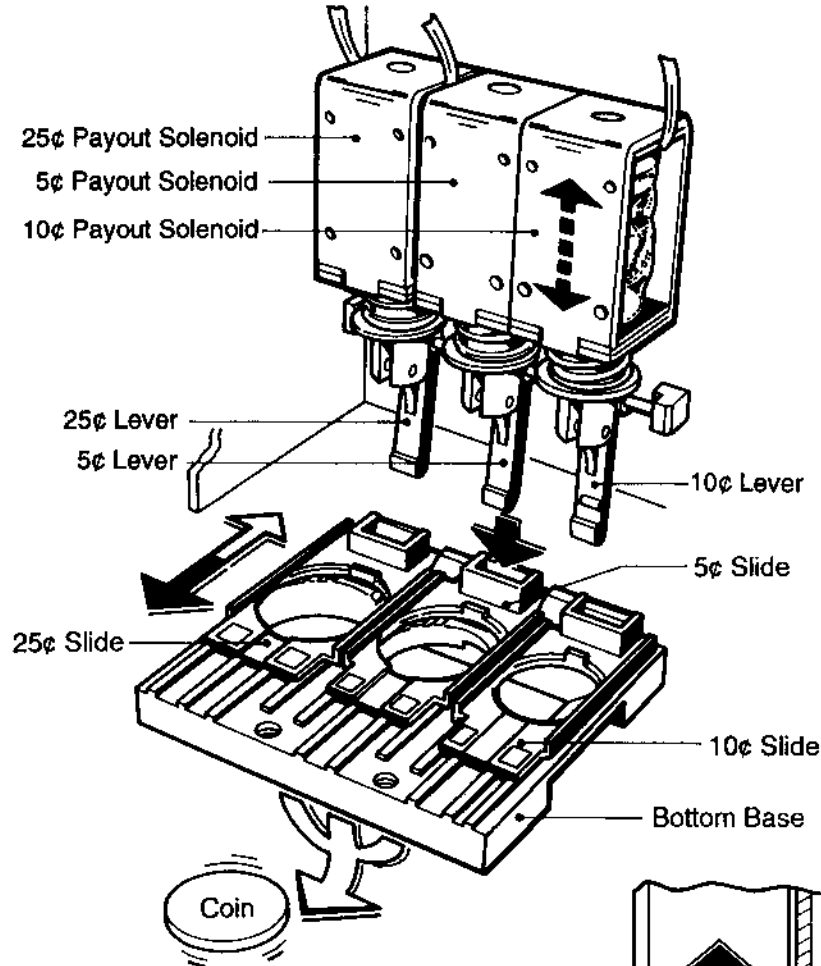

- 5¢ coin payout

Payout is made by the operation of the 5¢ payout solenoid .

The payout operation is described above.

- 10¢ coin payout

Payout is made by the operation of the 10¢ payout solenoid .

The payout operation is described above.

- 25¢ coin payout

Payout is made by the operation of the 25¢ payout solenoid .

The payout operation is described above.

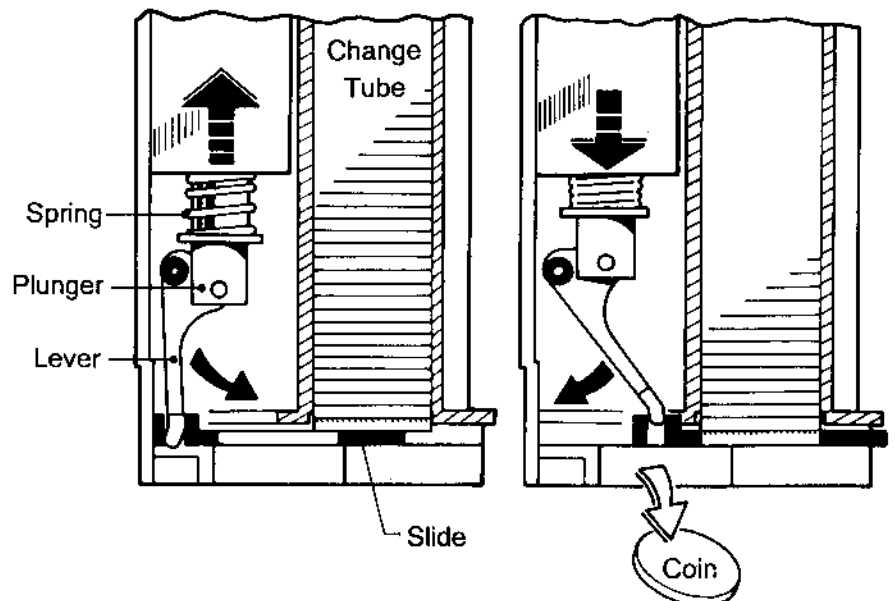

## 6-6 Input and Output Configuration

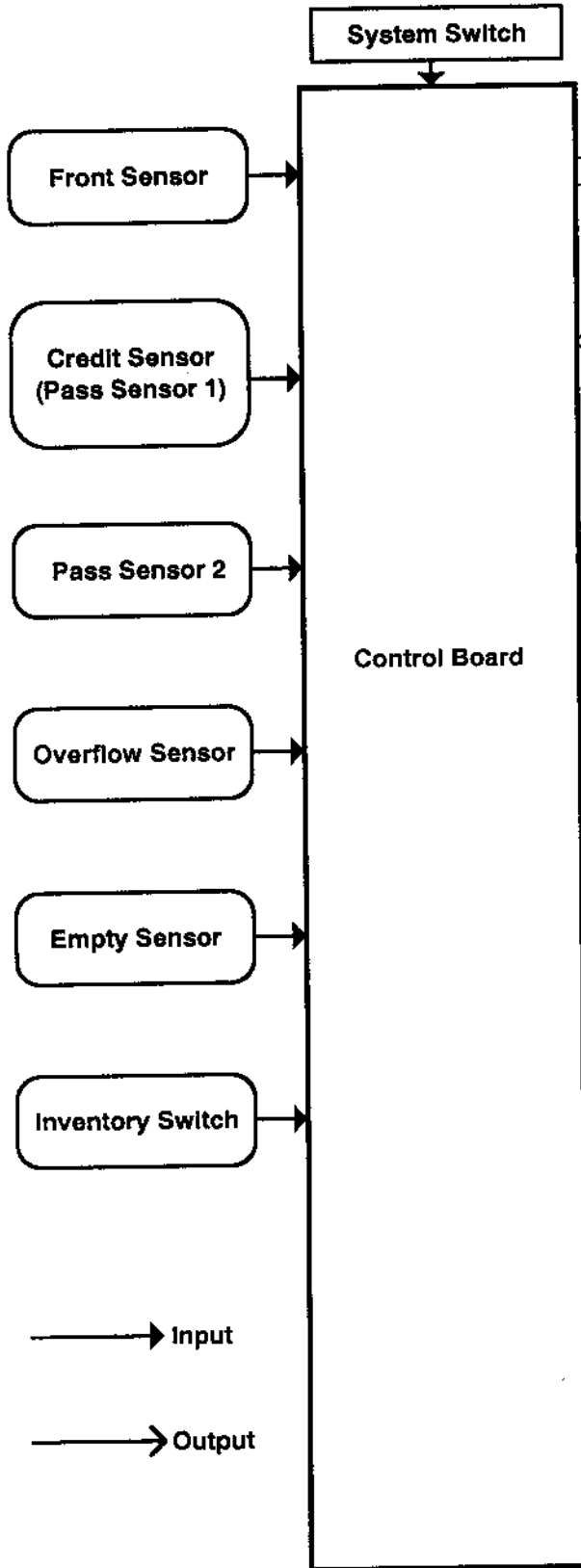

### • 12P Connector (USLX-001, USLX-002)

Terminal No.	Signal Name		Input / Output
	USLX-001	USLX-002	
1	Power Supply(+5VDC)		Input
2	Power Supply(0VDC)		Input
3	Send		Input
4	Interrupt		Output
5	Date		Output
6	Can Accept		Input
7	25¢ Payout		Input
8	10¢ Payout		Input
9	5¢ Payout		Input
10	Power Supply (-117VDC)	(-24VDC)	Input
11	Reset		Input
12	Power Supply (+117VDC)	(+24VDC)	Input

### • 15P Connector (USLX-004)

Terminal No.	Signal Name	Input / Output
1	Power Supply(+5VDC)	Input
2	Power Supply(0VDC)	Input
3	Send	Input
4	Interrupt	Output
5	Date	Output
6	Can Accept	Input
7	25¢ Payout	Input
8	10¢ Payout	Input
9	5¢ Payout	Input
10	N/C	---
11	Reset	Input
12	N/C	---
13	Power Supply(-24VDC)	Input
14	N/C	---
15	Power Supply(+24VDC)	Input

Note: The input / output column is as seen from the coin mechanism.

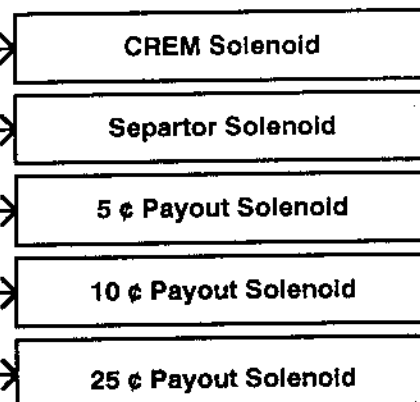

# 7. WIRING DIAGRAM

## 7 Wiring Diagram

### 7-1 USLX-001 Series

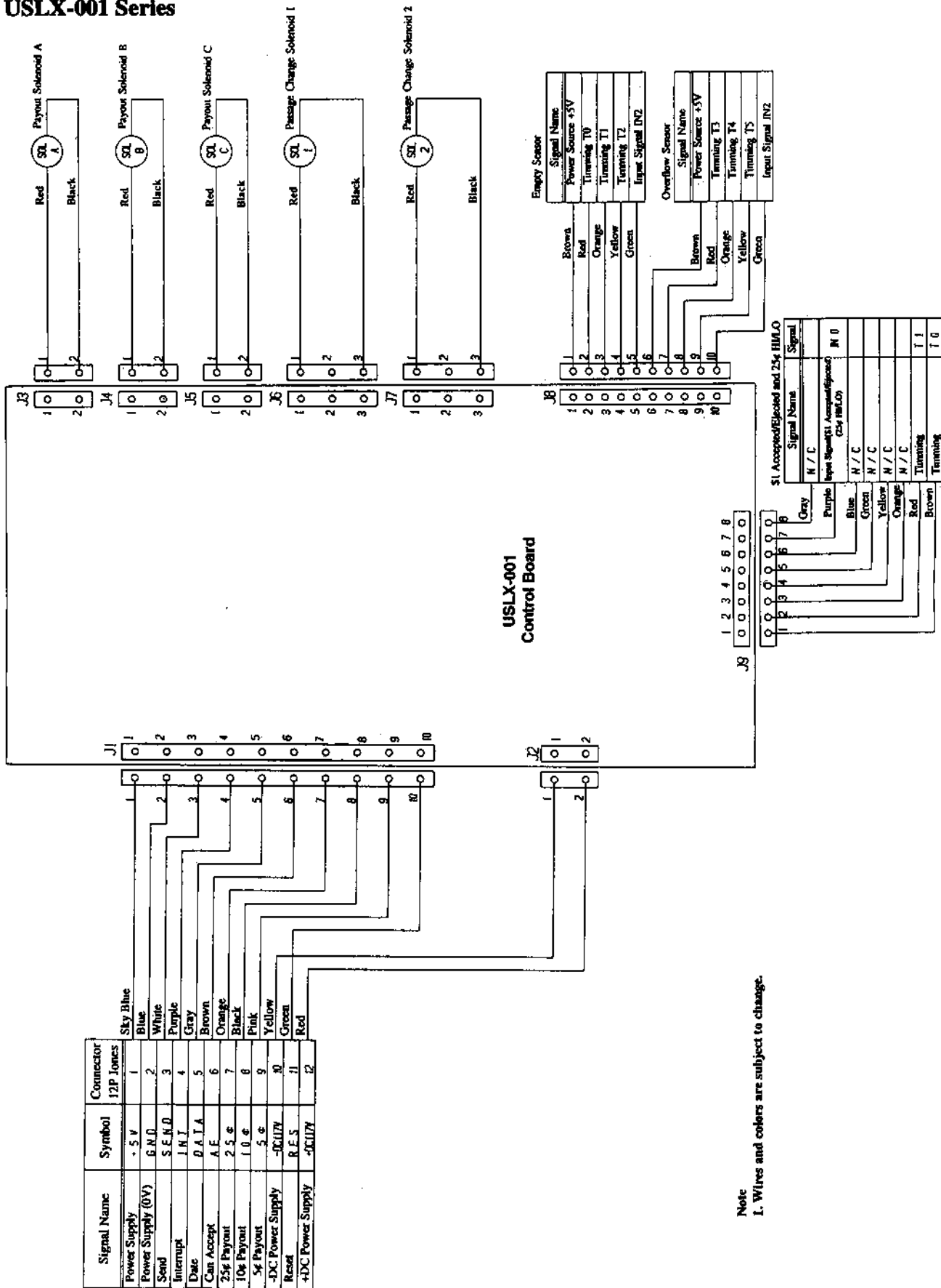

Note  
1. Wires and colors are subject to change.



## 7-2 USLX-002 Series

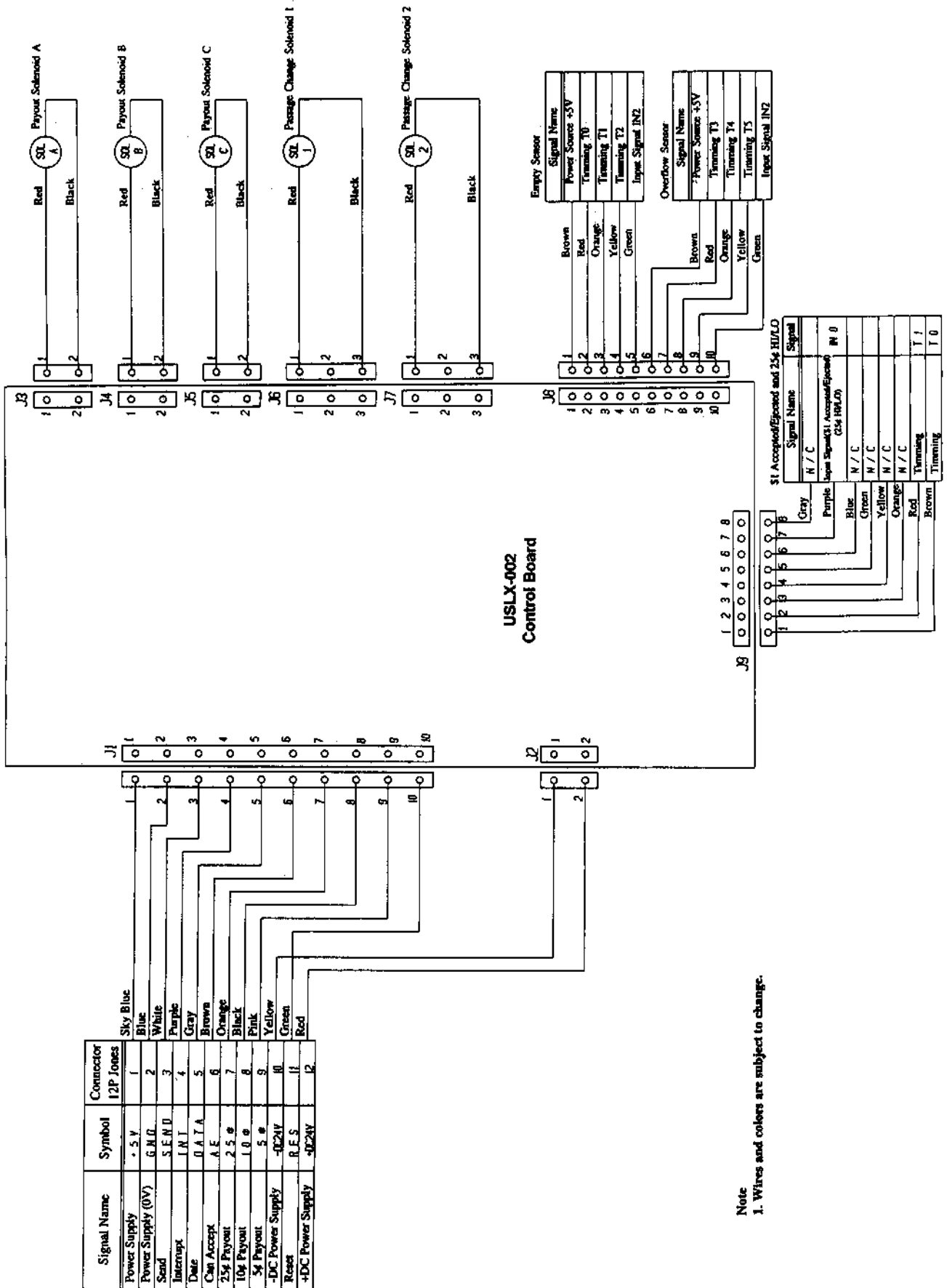

Note  
1. Wires and colors are subject to change.



## 8. PREVENTIVE MAINTENANCE

The coin changer can become dirty from coins, dust, foreign matter, etc. and good coin acceptance cannot be maintained.

Use mild soap water to remove sticky matter, syrup, etc. **NEVER USE SOLVENTS!**

### ● Disassembly and assembly of chute cover and chute

- ① The chute cover can be removed by releasing the 2 locking tabs on the right side from the housing.

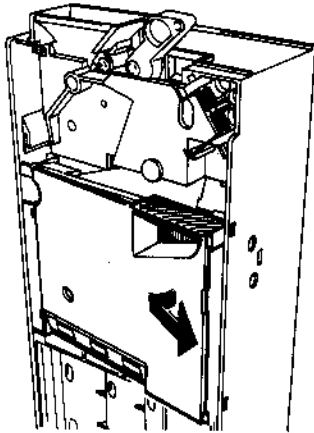

- ② The chute can be pulled out to the front after releasing the 2 locking tabs on the left side from the housing.

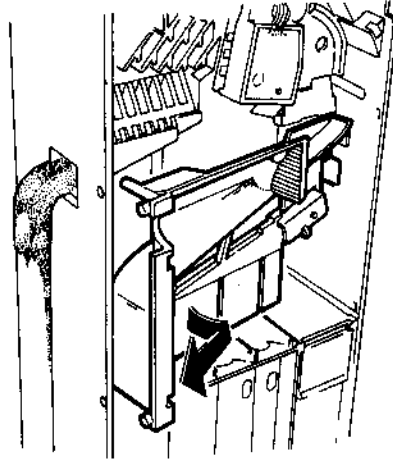

### ● Cleaning: Keep shaded areas clean.

- ① Cleaning the gate  
Open the gate assembly and use a dry cloth to remove any dirt from the coin path.

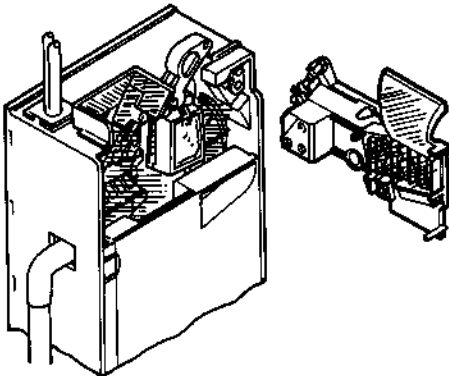

- ② Front sensor  
Open the front sensor and use a soft cloth or a cotton swab to remove any dirt. The front sensor is a precision part of the coin changer, care is required when opening or closing the sensor ass'y.

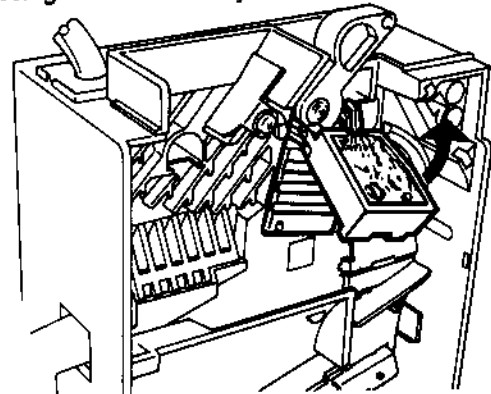

- ③ Cleaning of chute and housing
- Use a dry cloth to remove dirt from the coin path at the rear of the chute.
  - When cleaning the coin path of the housing, pay attention to the CREM and separator lever and other parts while wiping off any dirt.

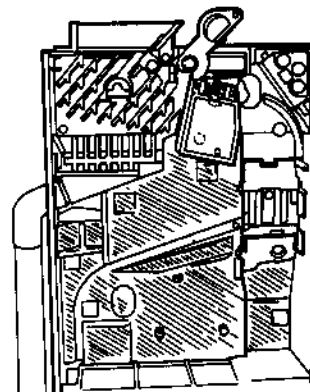
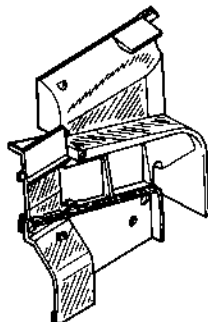

## 9. DISASSEMBLY AND ASSEMBLY PROCEDURE

Disassemble the coin changer in the order written, assemble in reverse order.

### 1. Removal of the Chute Cover .

Release the 2 locking tabs on the right side of the chute cover from the housing. Pull the chute cover out and to the right to remove.

- **Assembly Precautions:**

Insert the left side tabs of the chute cover into the chute first, then press the right side tabs into the housing.

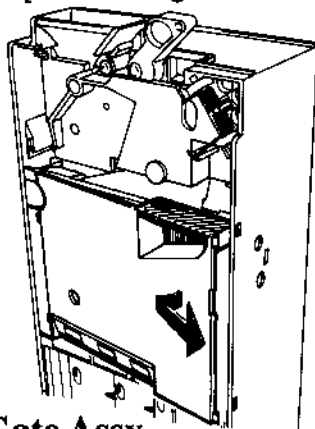

### 2. Removal of The Chute

Release the 2 locking tabs on the left side of the chute from the housing.

Pull the chute out and to the left to remove.

- **Assembly Precautions:**

Insert the right side tabs of the chute into the housing first, then press the left side tabs into the housing.

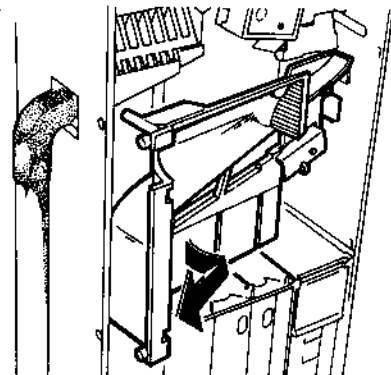

### 3. Removal of The Gate Assy

Release the gate spring by inserting a small screwdriver or scribe into the loop of the spring inside the housing, then pry the spring to the right and pull the gate out.

- **Assembly Precautions:**

When installing the gate, make sure the gate spring clips behind the housing.

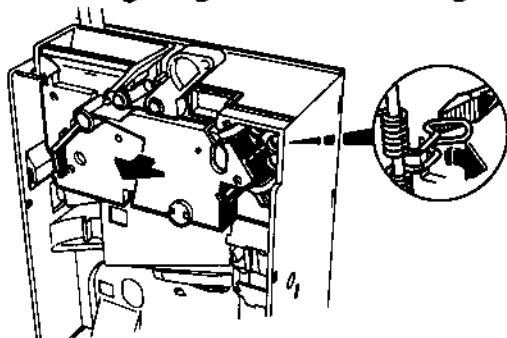

### 4. Removal of The Drain Spout

Lift up on the bottom of the drain spout and pull the left side out first.

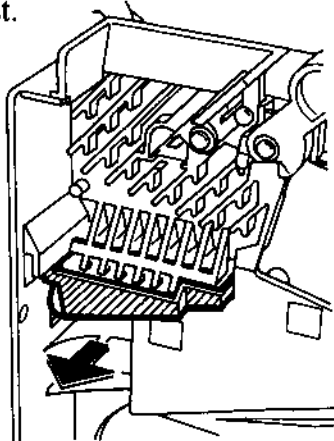

### 5. Removal of The Back Cover

Remove the 2 screws, pull the back cover out and to the right.

- **Assembly Precautions:**

Insert the left side tabs of the back cover into the side of the housing first.

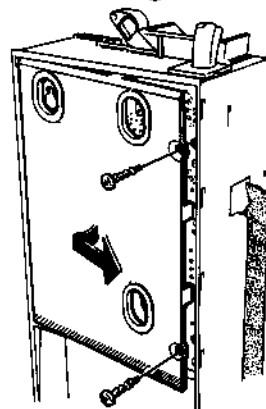

# 9. DISASSEMBLY AND ASSEMBLY PROCEDURE

## 6. Removal of The Control Board

Remove the 5 screws attaching the control board to the housing. Gently push the front sensor through the housing and unplug the connectors.

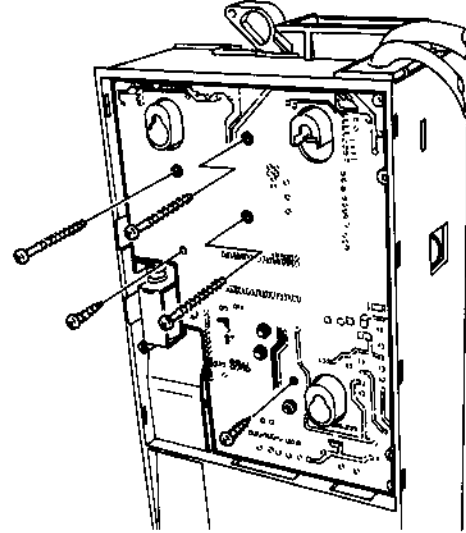

## 7. Removal of The Change Tube Assy.

Release the locking tabs on the left and right sides of the change tube assy from the housing, then pull out and up to remove.

● **Assembly Precautions:**

First, feed the wires through the housing, to the back side. Next insert the bottom of the change tube assy into the bottom of the housing, then the top.

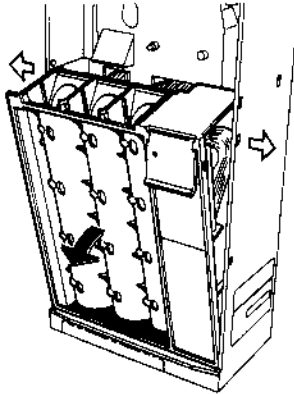

### ① Removal of The Inventory Board Assy

Remove the 2 screws attaching the inventory board to the change tubes.

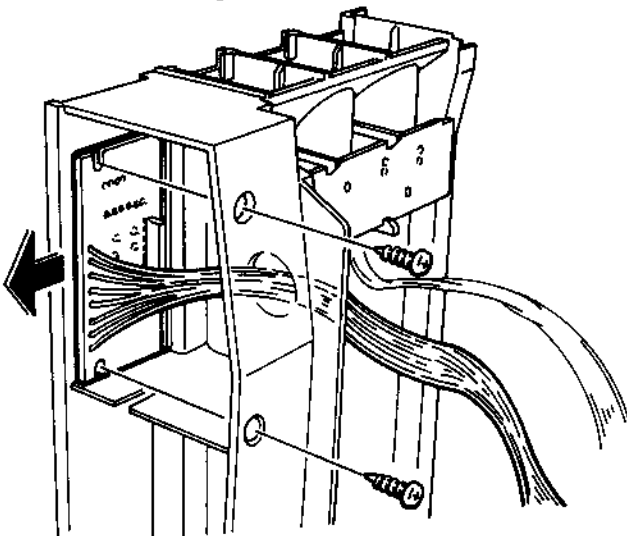

### ② Removal of The Sensor Board Assy

Carefully cut the cable tie attaching the wires to the latch. Spread the latches apart to remove the sensor board assy.

● **Assembly Precautions:**

Be careful not to damage the L.E.D. sensors when installing.

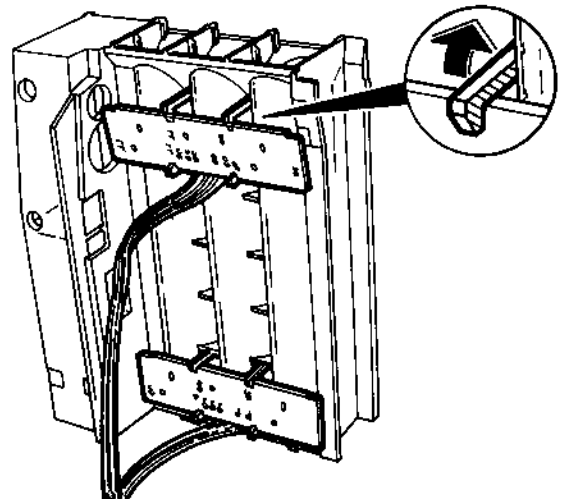

**9. DISASSEMBLY AND ASSEMBLY PROCEDURE****8. Removal of The Bottom Base and 5¢, 10¢ and 25¢ Slides**

Remove the 2 screws attaching the bottom base to the housing, then remove the 5¢, 10¢ and 25¢ slides

- **Assembly Precautions:**  
Insert the tabs of the bottom base into the back side of the housing, then the screws.

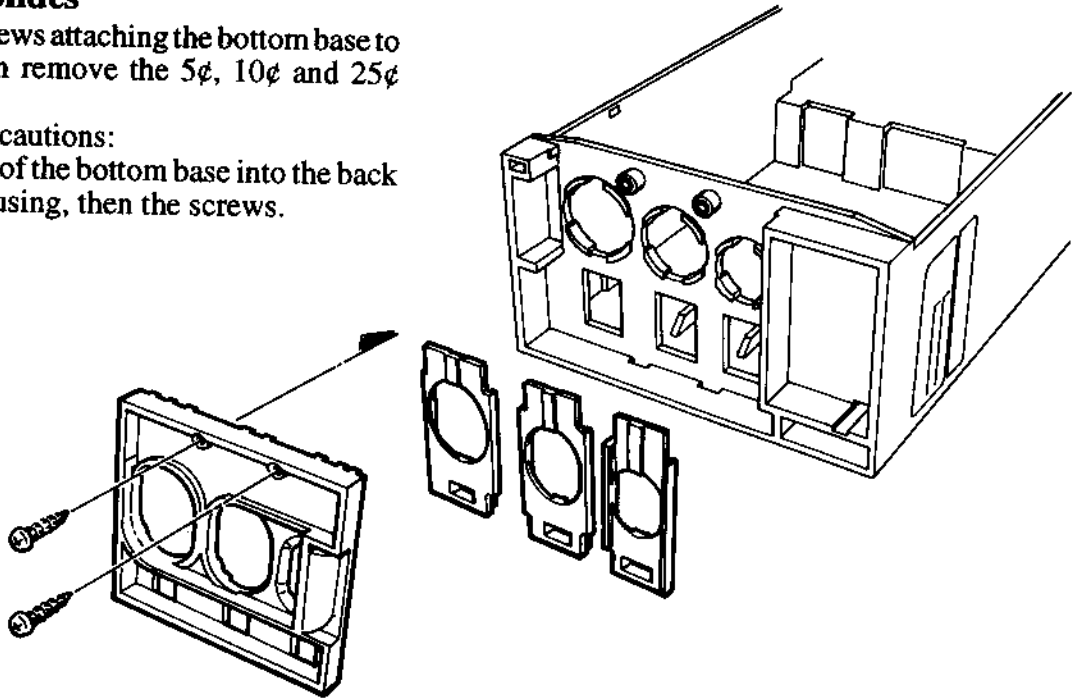
**9. Removal of The Payout Solenoids**

Remove the 2 screws attaching each solenoid to the housing.

- **Assembly Precautions:**  
Install the payout solenoids in the correct locations:  
1 = 25¢ (White connector),  
2 = 5¢ (Blue connector),  
3 = 10¢ (Black connector).  
Route the wires as shown.

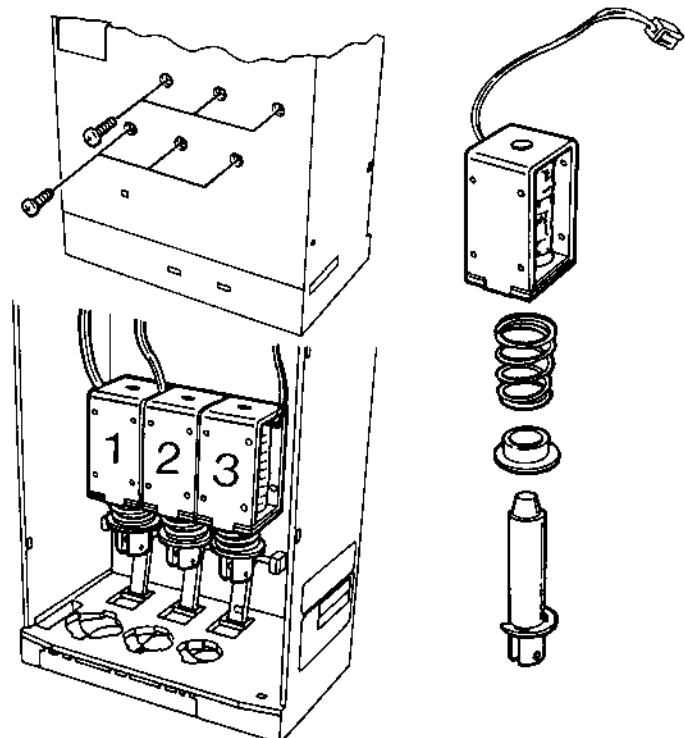

## 10. Removal of Levers (A), (B) and The Lever Shaft

Remove the retaining ring from the left side of the lever shaft, then slide it out of the housing.

- Assembly Precautions:  
Lever (B) must be installed in the 10¢ slot.

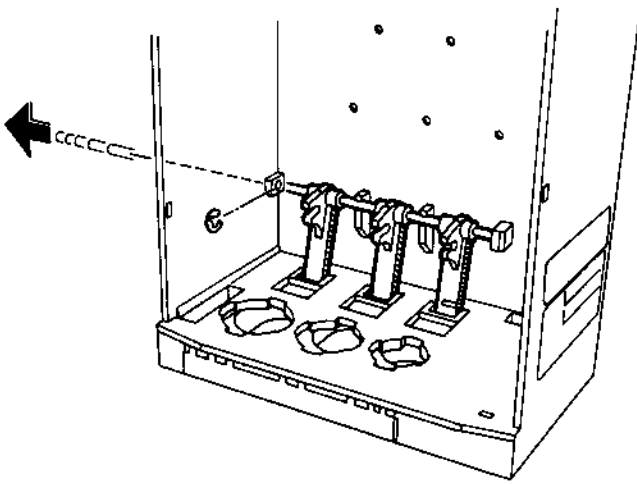

## 11. Removal of The Funnel Guide and Funnel

Remove the screw attaching the funnel guide, then remove the screw attaching the funnel to the housing.

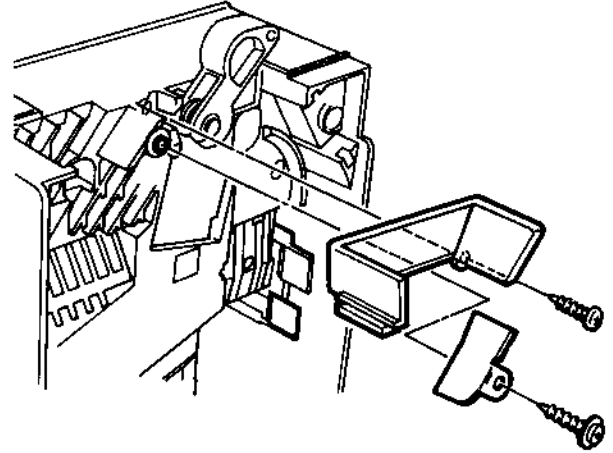

## 12. Removal of The Gate Lever and Spring

Remove the screw attaching the gate lever to the housing, then release the lever spring from the housing with a small screwdriver.

- Assembly Precautions:  
Insert the spring into the gate lever before assembling.

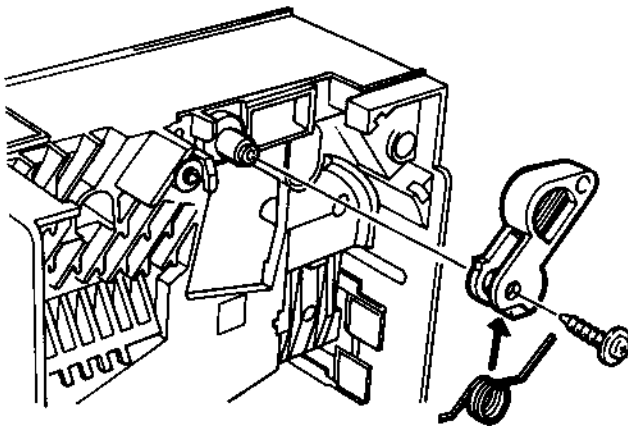

### 13. Removal of The CREM and Separator Solenoids

Remove the screws on the front side of the housing that attach the CREM and separator solenoids.

- Assembly Precautions:  
Make sure that the solenoid arm engages the lever for correct operation.

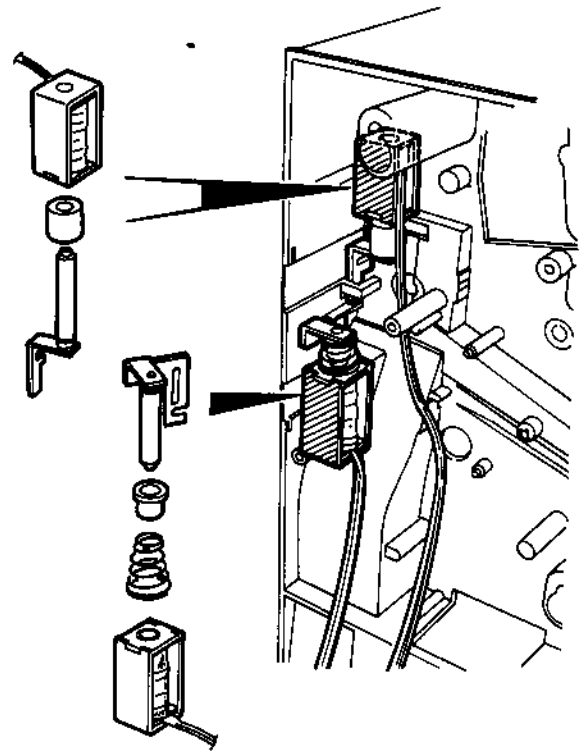

### 13-1. Removal of The CREM Extension and Separator Lever

Release the tab on the right side from the housing first, then remove.

- Assembly Precautions:  
Insert the left side tab first, then push the right side in place.

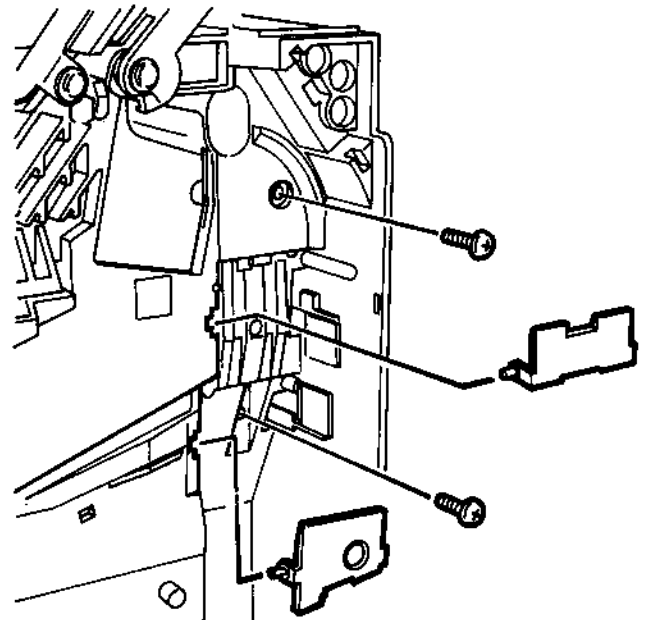



## 14. Removal of The Control Harness Assy

Remove the screw attaching the harness guide to the housing, then remove the harness guide from the side of the housing. Pull the control harness assy and bushing from the top of the housing.

- **Assembly Precautions:**

Make sure the harness bushing is seated properly in the top of the housing.

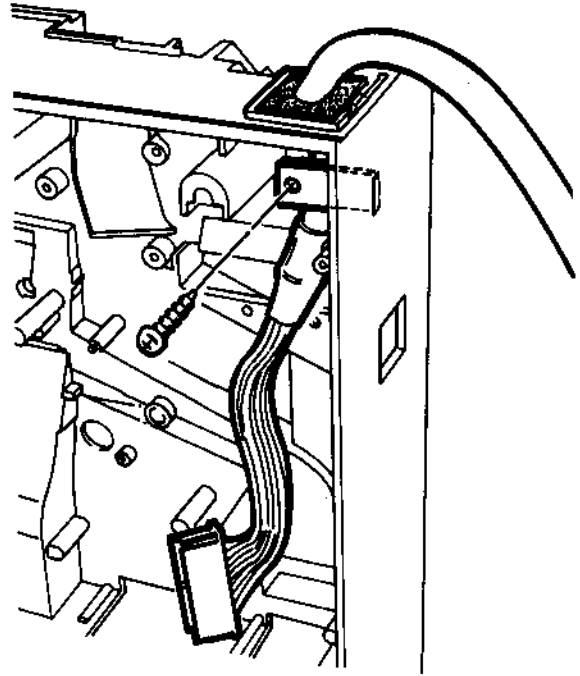

## 15. Removal of The Route Plates

Remove the 2 screws attaching the route plates to the right side of the housing.

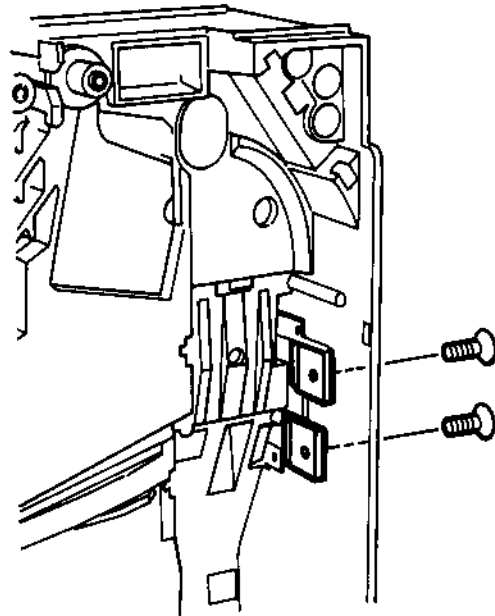

## 10. PARTS DIAGRAM AND PARTS LIST

## 10. PARTS DIAGRAM AND PARTS LIST

## 10-1 Changer (Front Side)

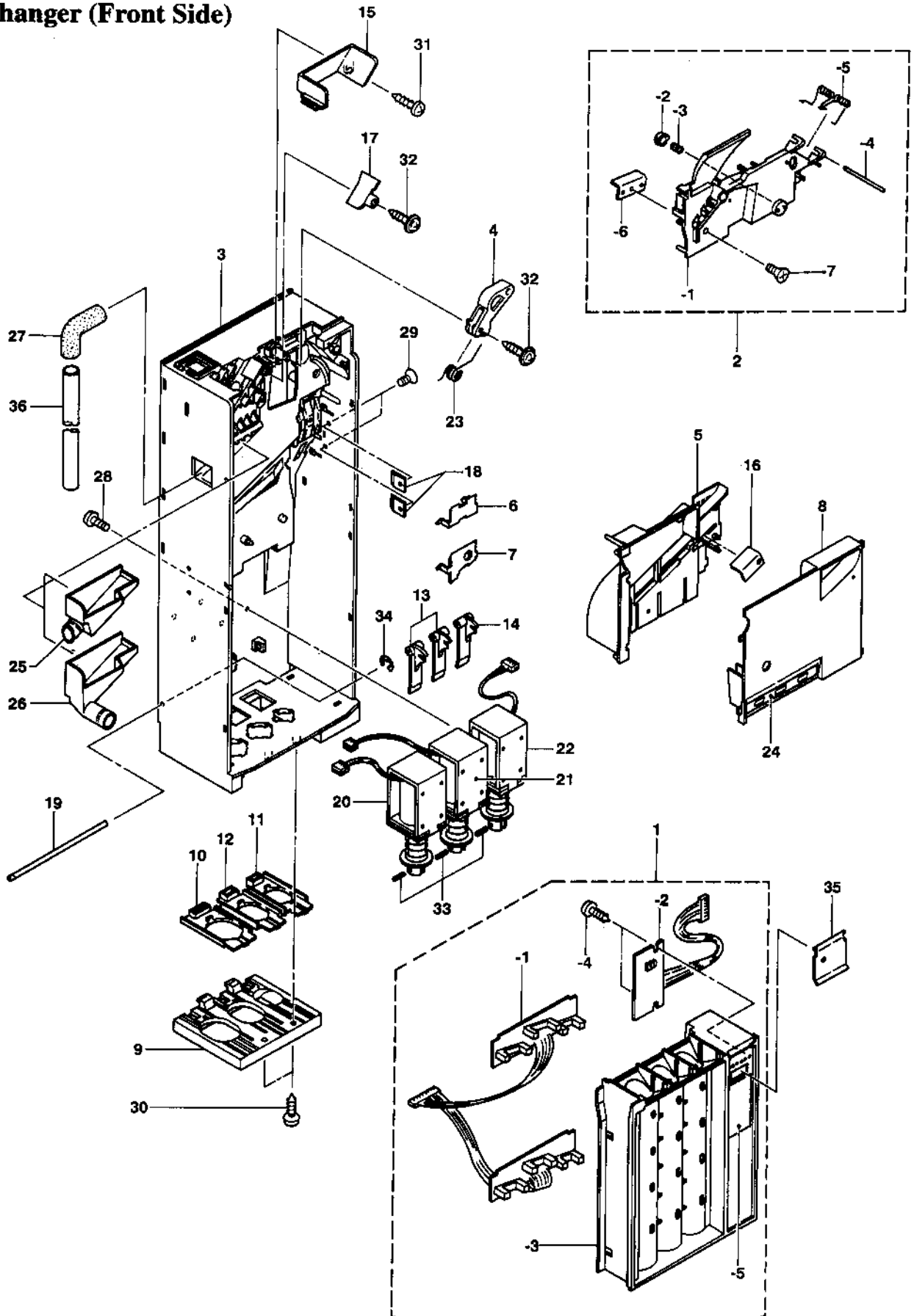

# 10. PARTS DIAGRAM AND PARTS LIST

USLX-1,2,4  
SERIES

27

INDEX NO.	PART NO.	DESCRIPTION	QTY			REMARKS
			USLX-1	USLX-2	USLX-4	
1		Change Tube ASSY				
1-1	252203	Sensor Board ASSY	1	1	1	
1-2	252224	Inventory Board ASSY	1	1	1	
1-3	252413	Change Tube	1	1	1	
1-4	904027	Self Tapping Screw	2	2	2	(+)Pan-head M3 X 6
1-5	252531	Seal (1)	1	1	1	
2		Gate ASSY				
2-1	252402	Gate	1	1	1	
2-2	252424	Coil Case Cap	1	1	1	
2-3	367509	Cap Spring	1	1	1	
2-4	361503	Gate Pin	1	1	1	
2-5	252505	Gate Spring	1	1	1	
2-6	252502	Gate Rail	1	1	1	
2-7	902003	Screw	1	1	1	(+)Flat-head M3 X 4
3	252432	Housing	1	1	1	
4	252431	Gate Lever (2)	1	1	1	
5	252406	Chute	1	1	1	
6	252407	CREM Extension	1	1	1	
7	252408	Separator Lever	1	1	1	
8	252412	Chute Cover	1	1	1	
9	252433	Bottom Base	1	1	1	
10	252434	25¢ Slide	1	1	1	
11	252435	10¢ Slide	1	1	1	
12	252436	5¢ Slide	1	1	1	
13	252418	Lever (A)	2	2	2	
14	252419	Lever (B)	1	1	1	
15	252422	Funnel	1	1	1	
16	252501	Chute Rail	1	1	1	
17	252503	Funnel Guide	1	1	1	
18	361510	Route Plate	2	2	2	
19	252504	Lever Shaft	1	1	1	
20	252749	Payout Solenoid (7)	1			25¢ (White Connector)
20	252756	Payout Solenoid (10)		1	1	25¢ (White Connector)
21	252750	Payout Solenoid (8)	1			5¢ (Blue Connector)
21	252757	Payout Solenoid (11)		1	1	5¢ (Blue Connector)
22	252751	Payout Solenoid (9)	1			10¢ (Black Connector)
22	252758	Payout Solenoid (12)		1	1	10¢ (Black Connector)
23	362505	Gate Lever Spring	1	1	1	
24	252512	Tube Seal	1	1	1	
25	252420	Drain Spout	1	1	1	Side Type
26	252426	Drain Spout(2)	1	1	1	Front Type
27	252428	Rubber Elbow	1	1	1	Front & Side Type
28	900008	Screw	6	6	6	(+)Pan-head M3 X 6
29	902003	Screw	2	2	2	(+)Flat-head M3 X 4
30	904211	Self Tapping Screw	2	2	2	(+)Pan-head M3 X 10
31	904209	Self Tapping Screw	1	1	1	(+)Pan-head M3 X 8
32	904804	Self Tapping Screw with Washer	2	2	2	(+)Pan-head M3 X 6
33	907927	Spring Pin	3	3	3	ø 3 X 12
34	907401	Retaining Ring	1	1	1	ø 1.9
35	252427	Price Switch Cover	1	1	1	
36	252526	Drain Tube	1	1	1	1ft.

## 10. PARTS DIAGRAM AND PARTS LIST

## 10-2 Changer(Rear Side)

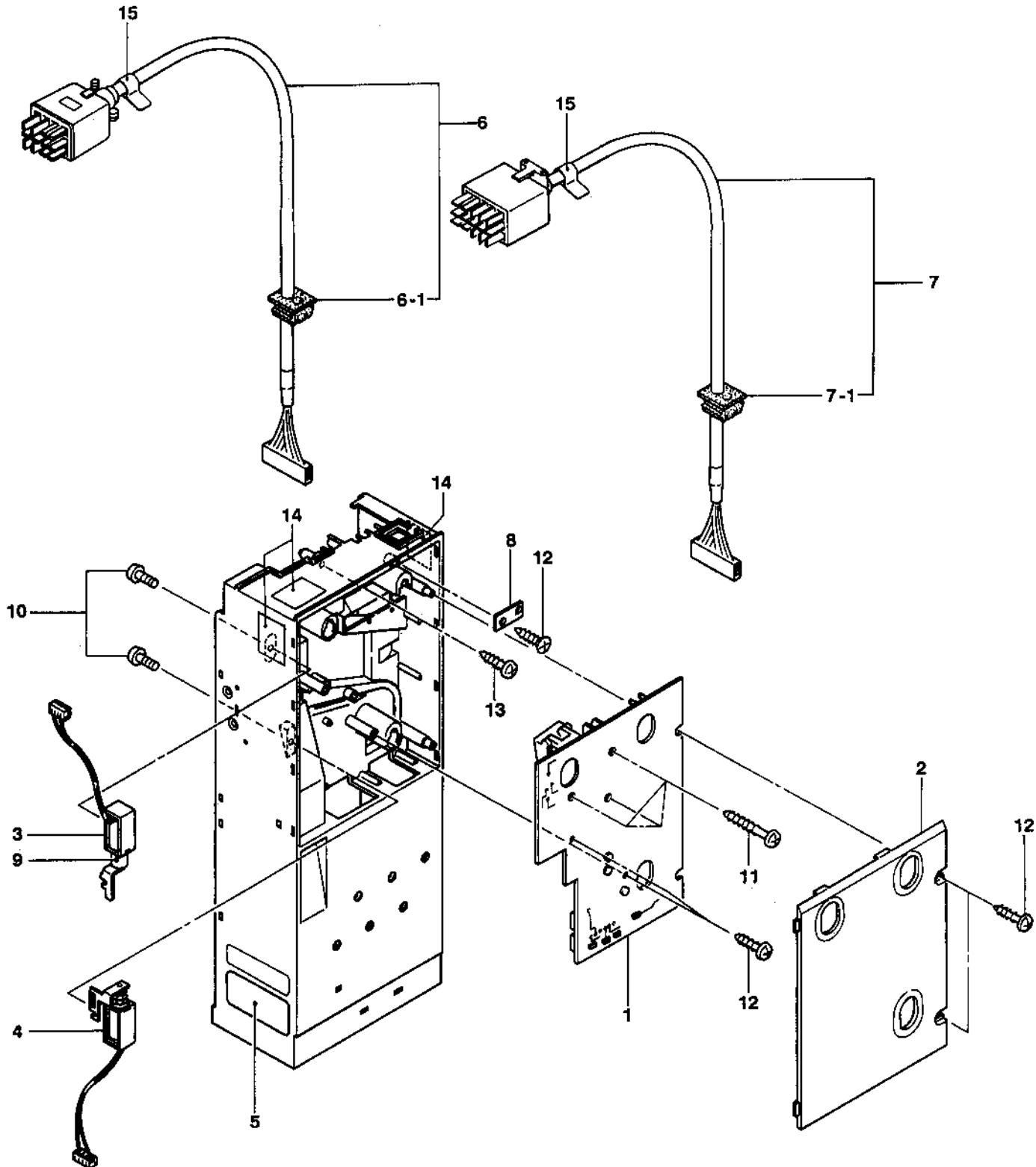

# 10. PARTS DIAGRAM AND PARTS LIST

**USLX-1,2,4  
SERIES**

**29**

INDEX NO.	PART NO.	DESCRIPTION	QTY			REMARKS
			USLX-1	USLX-2	USLX-4	
1	252225	USLX-001 Control Board ASSY	1			USLX-001
1	252227	USLX-002 Control Board ASSY		1	1	USLX-002, 004
2	252421	Back Cover	1	1	1	
3	252701	CREM Solenoid (1)	1			USLX-001
3	252736	CREM Solenoid (3)		1	1	USLX-002, 004
4	252702	Separator Solenoid (2)	1			USLX-001
4	252737	Separator Solenoid (4)		1	1	USLX-002, 004
5	252529	Machine Nameplate (3)	1			USLX-001
5	252530	Machine Nameplate (4)		1	1	USLX-002, 004
6	252344	Control Harness ASSY	1	1		USLX-001, 002
6-1	252507	Rubber Bushing	1	1		
7	252348	Control Harness (2) ASSY			1	USLX-004
7-1	252507	Rubber Bushing			1	
8	252524	Harness Guide (3)	1	1	1	
9	252520	Solenoid Collar	1	1	1	
10	900006	Screw	2	2	2	(+)Pan-head M3 X 4
11	904214	Self Tapping Screw	3	3	3	(+)Pan-head M3 X 30
12	904209	Self Tapping Screw	5	5	5	(+)Pan-head M3 X 8
13	904208	Self Tapping Screw	1	1	1	(+)Pan-head M3 X 6
14	252532	Seal (2) (24V DC Only)		3	3	USLX-002, 004
15	252533	Harness Seal	1	1	1	

# 11. EXTERNAL VIEW AND DIMENSIONS

## 11. EXTERNAL VIEW AND DIMENSIONS

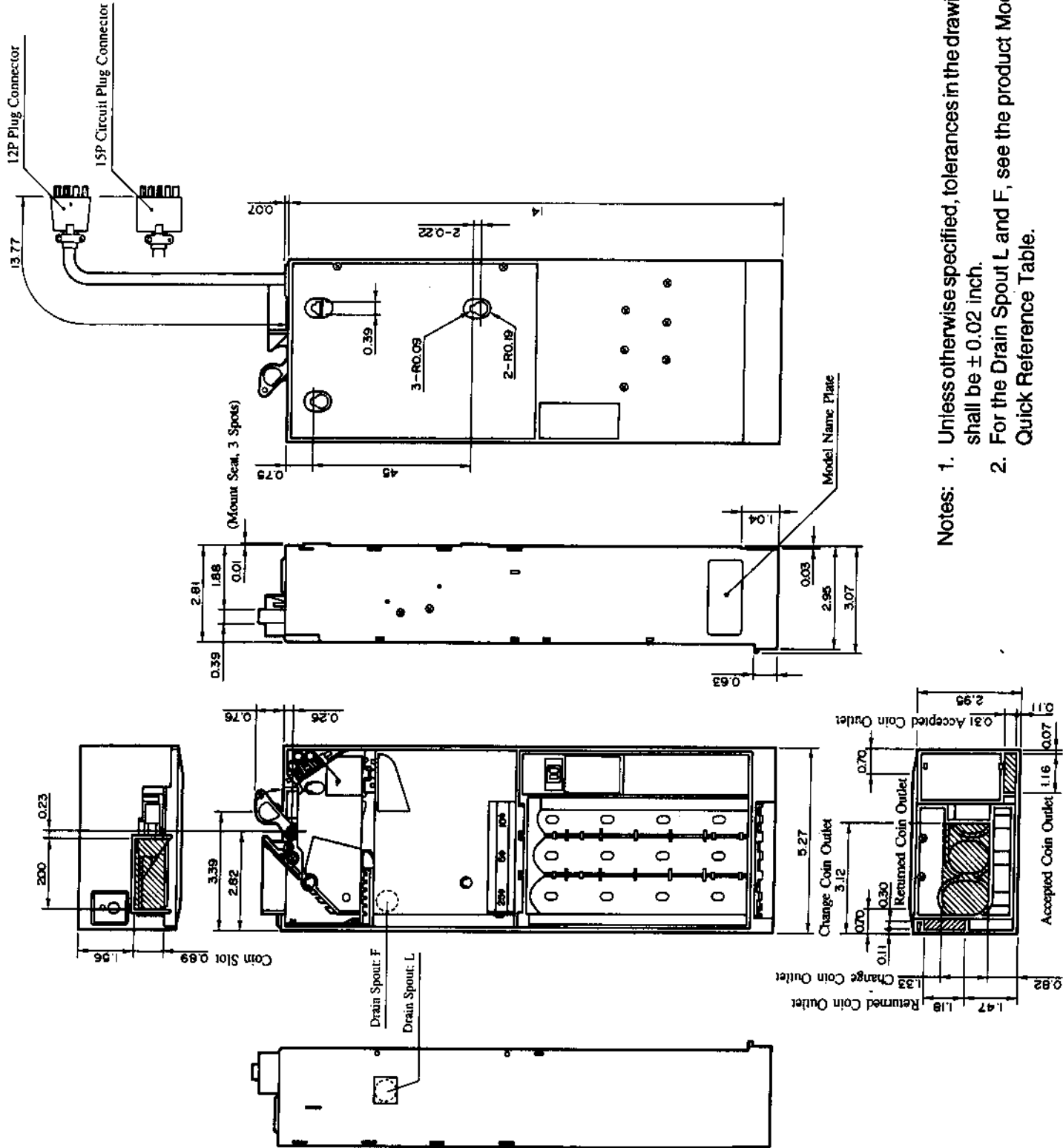

Notes: 1. Unless otherwise specified, tolerances in the drawing shall be  $\pm 0.02$  inch.  
2. For the Drain Spout L and F, see the product Model Quick Reference Table.