

CONLUX

Multi Drop Bus 3Tube Coin Changer

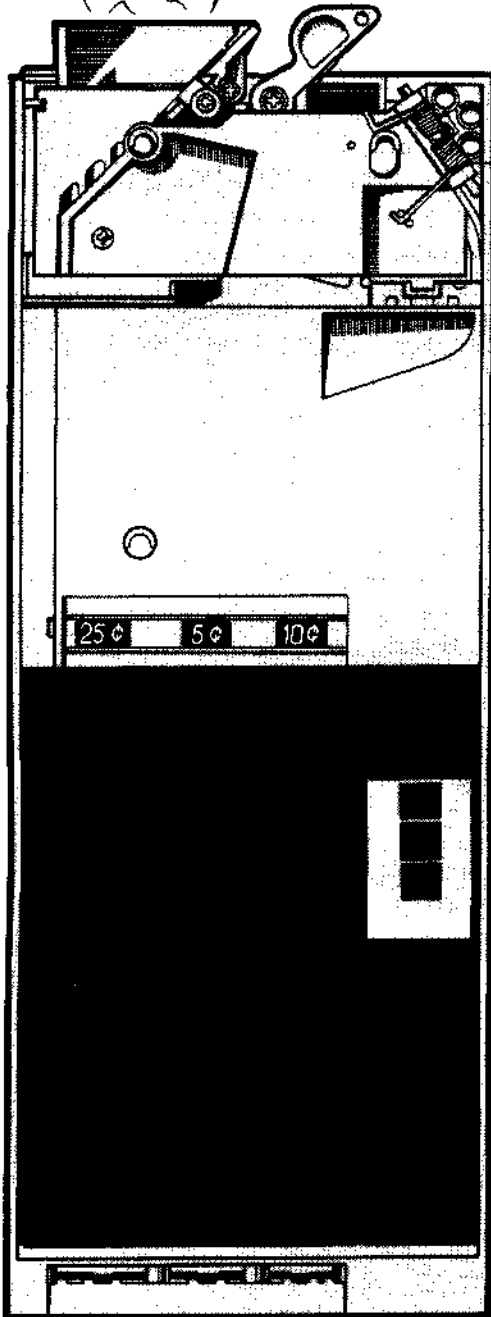

USLZ-1 Series



Service Manual

CONLUX USA CORPORATION

TABLE OF CONTENTS

	Page
1 Outline	3
Warranty	3
2 General Specifications	4
3 Detailed Specifications	4
4 Model No.	5
5 Handling and Installation	6
5-1 Handling Instructions	6
5-2 Names of the Parts and their Functions	6
5-3 Installation Procedure	7
5-4 Loading the Change Tubes	7
5-5 Change Inventory	7
5-6 Vend Test	8
6 Construction and Description	8
6-1 Description of Parts	8
6-2 Flow of Coins	9
6-3 Discriminator Coin Paths	10
6-4 Discrimination Method	11-12
6-5 Operation of Switches, Sensors, and Parts	13-14
6-6 Payout System	15
7 Wiring Diagram	16
7-1 Connection Terminal Signal Conditions	16
8 Preventive Maintenance	17
9 Disassembly and Assembly Procedure	18-22
10 Parts Diagram and List	23-26
10-1 Changer (front side)	23-24
10-2 Changer (rear side)	25-26
11 External View and Dimensions	27

NOTE: TECHNICAL SUPPLEMENT AVAILABLE UPON REQUEST

1. OUTLINE

- The USLZ-series electronic coin changers, accepts: U.S. 5¢, 10¢, 25¢, and \$1.00 coins. It automatically stores 5¢, 10¢, 25¢, for change in coin tubes.
- This coin changer has special interface protocol. Multi-Drop-Bus (M.D.B.) for Soft Drink machine controllers.
- All USLZ-series coin changers have built-in water protection, draining off water to the side or front, preventing serious damage to vital parts of the changers.

Warranty

CONLUX USA CORPORATION warrants all new equipment (coin changers and bill validators) sold by it to be free from defective material and workmanship. Conlux will repair or replace (at its option) any part of the equipment which proves to be defective in materials or workmanship within a period of twenty-four (24) months from the date of original shipment from Conlux USA. This warranty includes salt water damage for twelve (12) months only from the date of original shipment from Conlux USA.

Other conditions applying to this warranty are as follows:

1. This warranty will not apply to any equipment which has been, in Conlux's opinion, subject to: accident, abuse, misuse, neglect, improper installation, vandalism, or improper maintenance or repair by unauthorized service personnel; or is found to include parts other than genuine Conlux USA-supplied parts or options.
2. Conlux will not be responsible for any expense incurred by the purchaser incidental to the repair or replacement of equipment covered by this warranty.
3. Freight charges to send the equipment to Conlux or a Conlux-appointed Independent Authorized Service Center for warranty service will be the responsibility of the purchaser.
4. THIS WARRANTY IS IN LIEU OF ALL OTHER WARRANTIES ORAL OR WRITTEN, EXPRESSED OR IMPLIED, INCLUDING WITHOUT LIMITATION, WARRANTIES OF MERCHANTABILITY, WARRANTIES OF FITNESS OF PURPOSE, AND ALL OTHER OBLIGATIONS OR LIABILITIES OF CONLUX. CONLUX NEITHER ASSUMES NOR AUTHORIZES ANY PERSON TO ASSUME FOR IT, ANY OTHER OBLIGATION OR LIABILITY IN CONNECTION WITH THIS WARRANTY POLICY.
5. LIABILITY TO CONLUX USA AND ITS APPOINTED INDEPENDENT AUTHORIZED SERVICE CENTER IS LIMITED TO THE REPAIR OR REPLACEMENT, AT THEIR OPTION, OF DEFECTIVE PARTS WITHIN THE CONLUX USA PRODUCT(S) AND DOES NOT INCLUDE INCIDENTAL AND CONSEQUENTIAL DAMAGES.

2. GENERAL SPECIFICATIONS

Specifications and design are subject to change without notice.

Items	USLZ-001 Series
Coins Accepted	U.S. 5¢, 10¢, 25¢, \$1 coins
Coins Paid Out	5¢, 10¢, 25¢ coins (automatic replenishment)
Coin Tube Capacity	5¢ coins approx. 74 ±3 coins 10¢ coins approx. 103 ±3 coins 25¢ coins approx. 77 ±3 coins
Change Payout	DC Solenoid (5, 10, 25¢ tubes)
Power Supply	DC 34 V
Insulation Resistance	20MΩ or greater
Operating Temperature Range	+5°F ~ 140°F
Rated Power Consumption	0.2A (Wait State) 2.2A (Operate State)
Weight	5 Lbs.

3. DETAILED SPECIFICATIONS**1 Payout System**

1.1 Types of Change 5¢, 10¢, 25¢ coins (automatic replenishment)

1.2 Payout System DC Solenoid

1.3 Coin Tube Capacity

5¢ coins approx. 74 ±3 coins

10¢ coins approx. 103 ±3 coins

25¢ coins approx. 77 ±3 coins

1.4 Coin Payout

Coins are paid out, based on payout signals, from the machine controller.

2 Change Detection

Coins are detected by sensors in the payout tubes and by the empty counter, counting coins inserted through the discriminator section of the coin changer routed into the tubes.

An empty out of change condition is assumed when:

- a. The lower sensors in the tubes detect no coins
- b. The empty counter shows less than 8 coins

3 Function of the Upper Sensors in the Tubes

If the coins in the tubes reach the upper sensors, the following inserted coins are then guided to the cash box.

NOTE: COINS ROUTED TO THE CASH BOX ARE REPORTED TO THE MACHINE CONTROLLER.

4 Coin Rejection

In the following cases, inserted coins are rejected:

- (1) When the power is off (power failure).
- (2) When the coin accept signal is cut off.
- (3) When the coins are being paid out.

5 Escrow Function

5.1 All accepted genuine coins are stored in the change tubes. (Excluding \$1 coins which are routed to the cash box.)

5.2 Pressing the coin return lever, results in the return of the coins in the denominations which were accepted.

However, if a \$1 coin is accepted, 25¢, 10¢, or 5¢ coins will be returned.

4. MODEL NUMBER

The product model name is shown in the table below. Select the model which you require from this table.

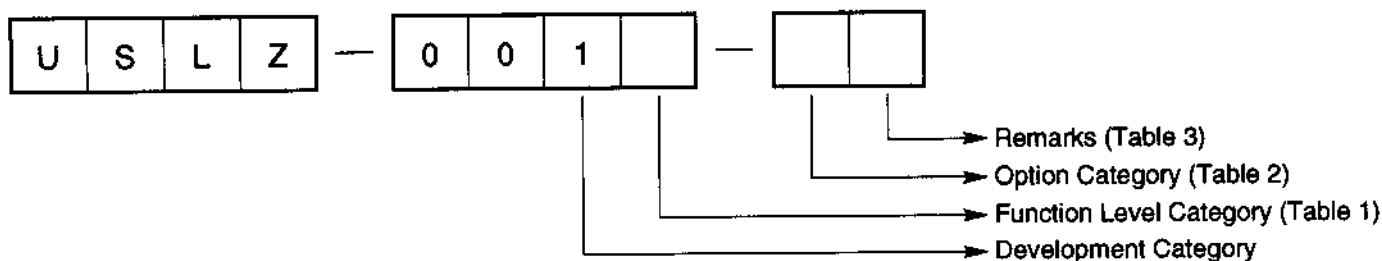

Table 1 Function Level Section

0	Level 3
Ⓐ	Level 2

Table 3 Remarks

L	Left Side Drain Spout
F	Front Drain Spout

Table 2 Option category

	Drain Tube	Price Switch Cover	Attached Parts
0	✓	✓	✓
1			✓
2		✓	✓
3	✓		✓

Attached Parts

L	Drain Spout (2) Rubber Elbow
F	Drain Spout Rubber Elbow

5. HANDLING AND INSTALLATION

5-1 Handling Instructions

Do not carry the coin changer by the harness.

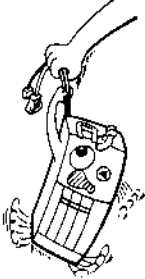

Do not drop the coin changer.

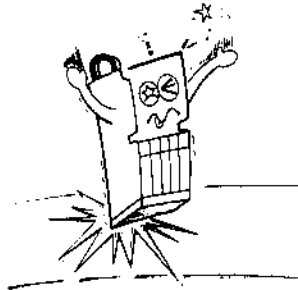

Handle the gate assembly gently when opening and closing by hand.

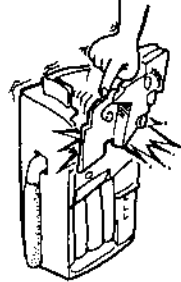

Store the coin changer in a dry, clean location.

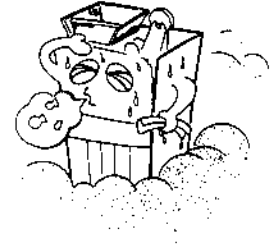

5-2 Names of the Parts and their Functions

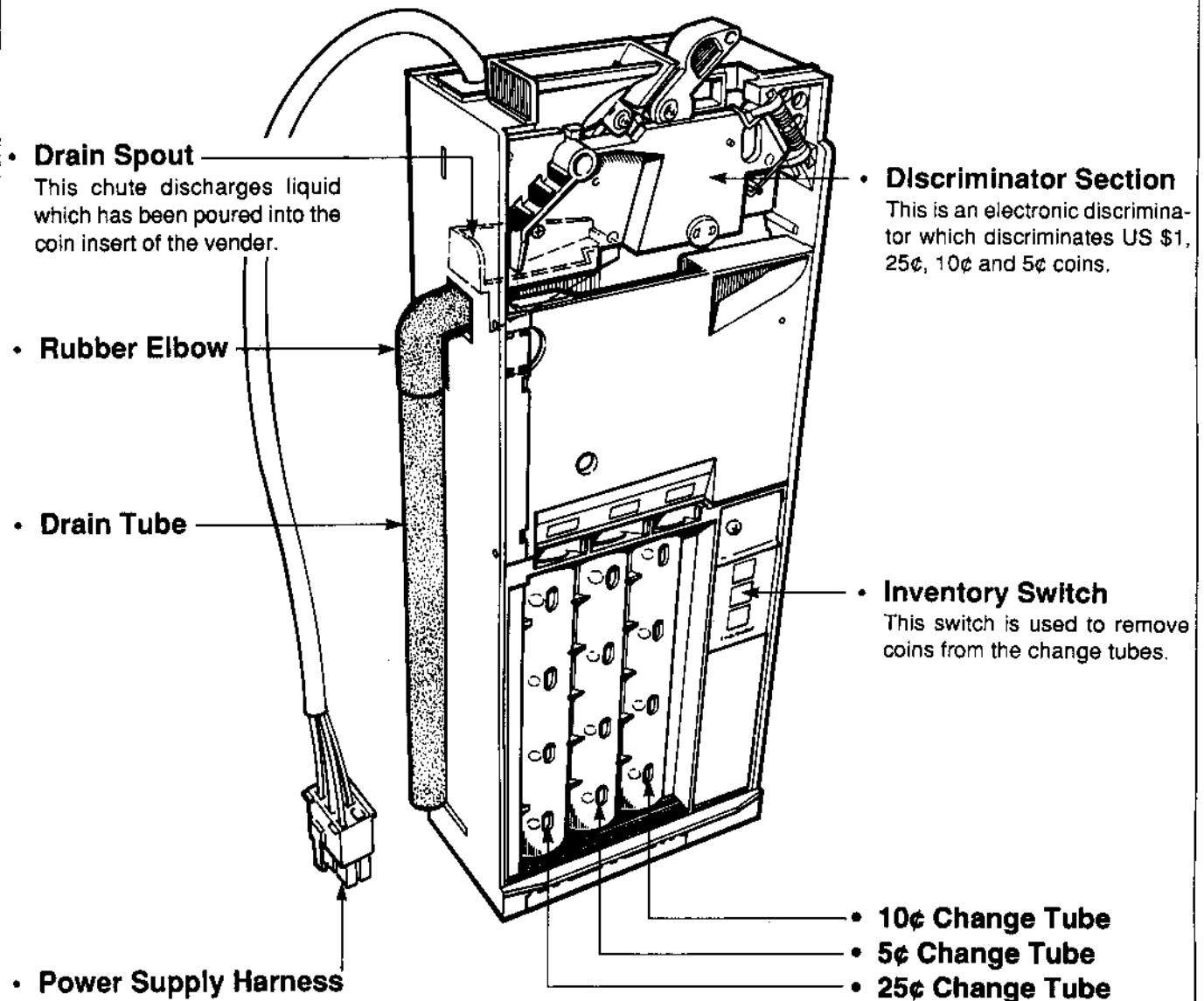

5-3 Installation Procedure

1. Attach the changer by aligning the key holes with the mounting screws on the vending machine, and fasten securely.

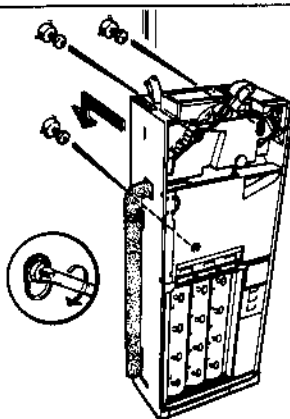

NOTE:
THE DISCRIMINATOR CAN
NOT BE REMOVED FROM
THIS COIN CHANGER.

2. Connect the 6 pin plug into the vending machine socket.

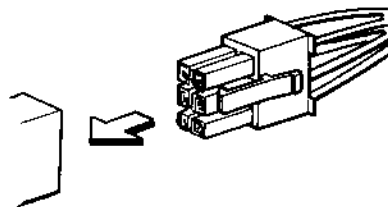

CAUTION: DO NOT PLUG OR UNPLUG COIN CHANGER WITH POWER ON.

5-4 Loading The Change Tubes

- Loading 5¢, 10¢ and 25¢ Coins

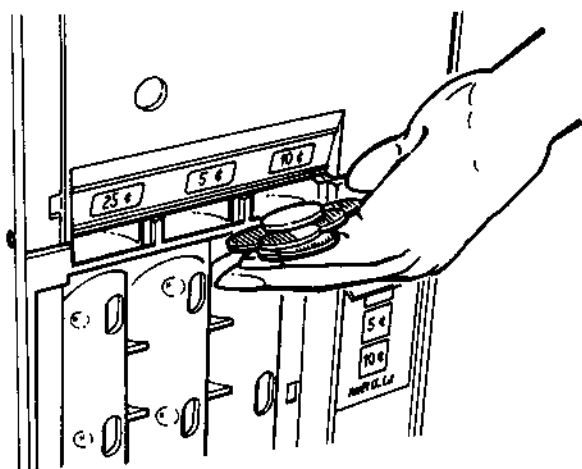

Quarters
25¢



Nickels
5¢



Dimes
10¢



Note:

- ① If a coin drops and stands on end, correct it.
- ② Be careful not to load bent coins.

5-5 Change Inventory

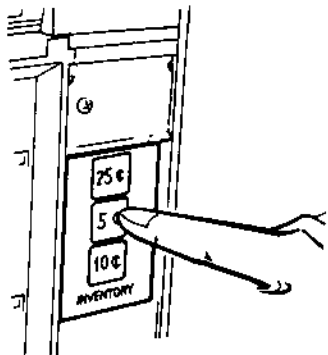

Coins Paid Out Manually

- 5¢ coins When the 5¢ inventory switch is pushed, 5¢ coins are paid out automatically.
- 10¢ coins When the 10¢ inventory switch is pushed, 10¢ coins are paid out automatically.
- 25¢ coins When the 25¢ inventory switch is pushed, 25¢ coins are paid out automatically.

* When the inventory switch is pushed ON, the payout solenoid operates. Pressing the inventory switch again will shut OFF the payout solenoid.

5-6 Vend Test

- ① Connect the 6-pin plug into the vending machine socket.
- ② Load coins into the respective change tubes.
5¢ tube → 20 coins, 10¢ tube → 20 coins, 25¢ tube → 15 coins.
The empty light on the vending machine should be off.
- ③ Insert different combinations of 5¢, 10¢, and 25¢ coins through the coin insert of the vending machine.
Vend a product when sufficient credit is established. Change will be returned in case of over credit.
- ④ Insert 1 → 5¢ coin. Press the coin return lever, a 5¢ coin should be returned.
- ⑤ Operate the inventory switches to empty the change tubes.

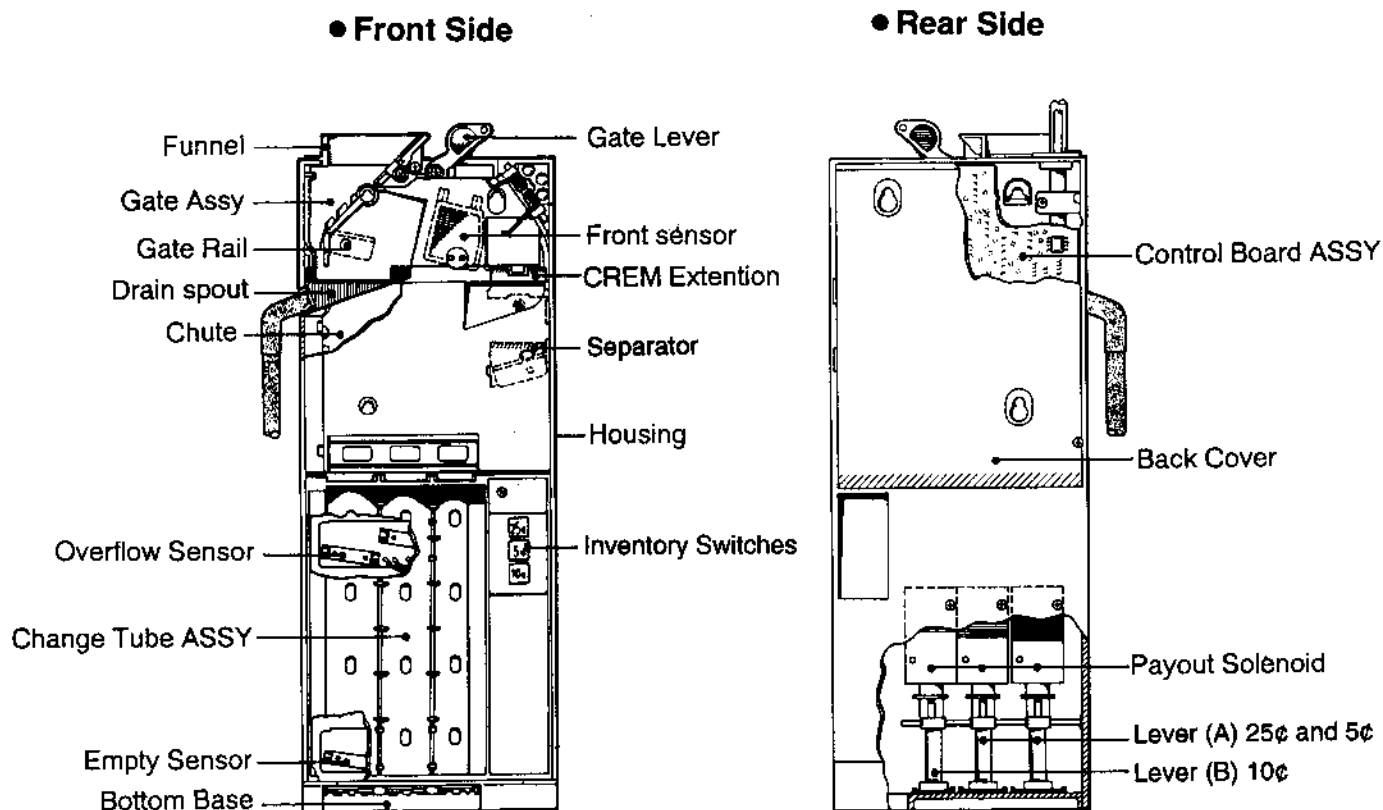
6. CONSTRUCTION AND DESCRIPTION**6-1 Description of Parts**

6-2 Flow of Coins

- The front sensor evaluates each inserted coin, if judged genuine, the CREM solenoid operates and the coins are routed past the credit sensor to the tubes.
- \$1.00 coins are always routed to the cash box.
- Defective coins or slugs are returned, either automatically or by operating the release lever.
- When the upper sensors (overflow sensors), detect coins in the tubes, additional coins will be routed to the cash box.

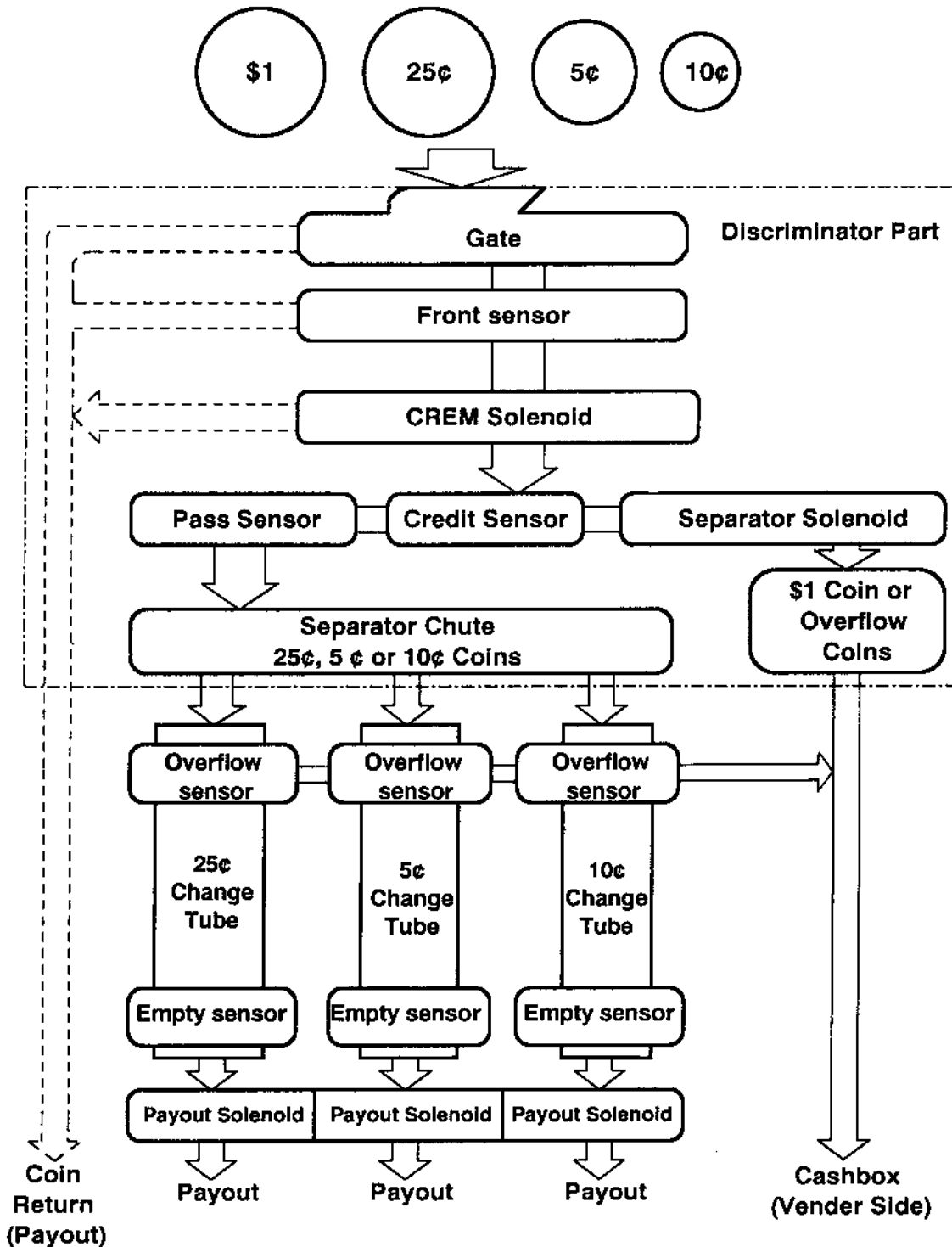

6. CONSTRUCTION AND DESCRIPTION

6-3 Discriminator Coin Paths

The electronic coin discriminator section judges whether 5¢, 10¢, 25¢ and \$1 coins are genuine or fake, separates them and credits the good coins.

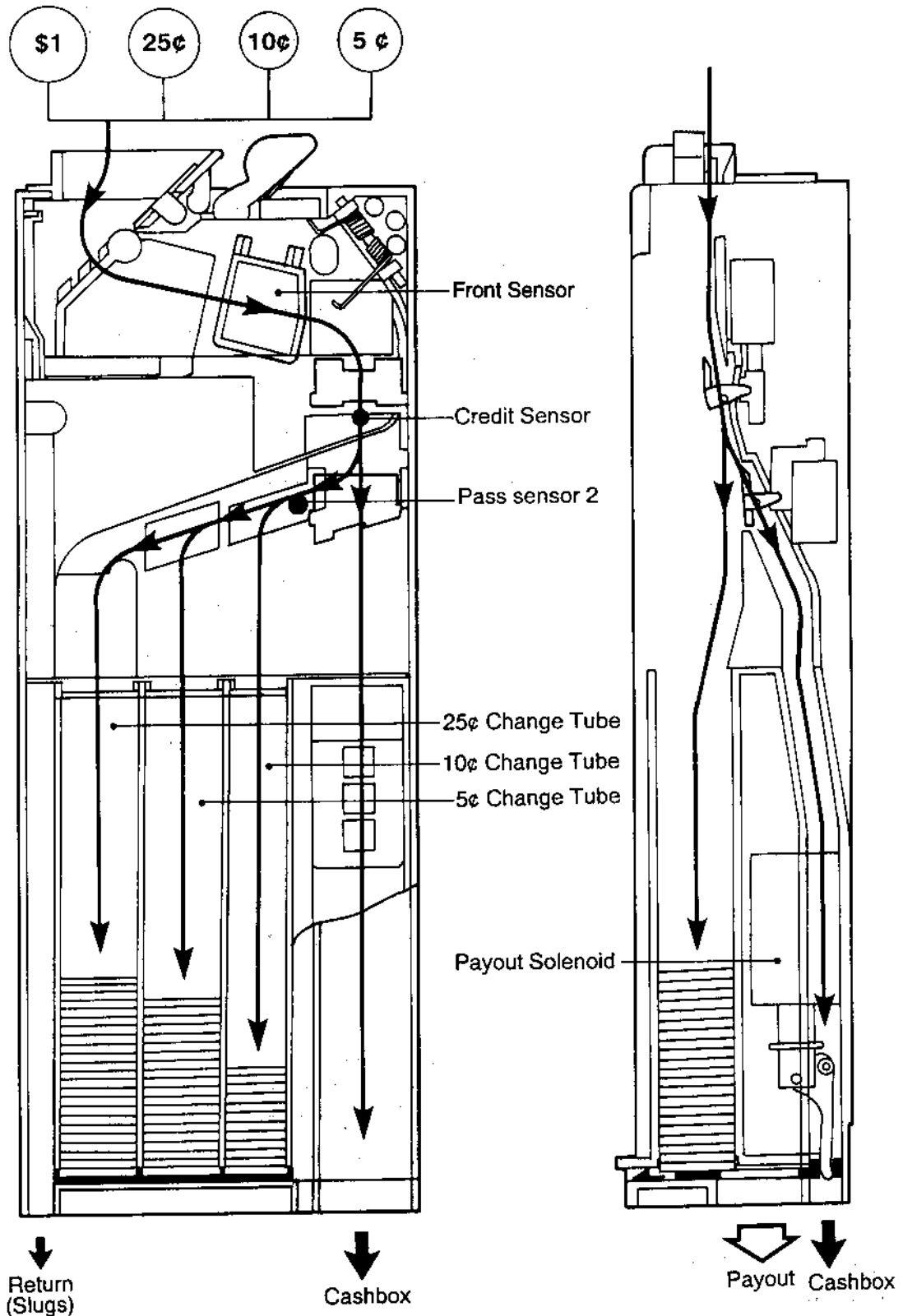

6-4 Discrimination Method

6-4-1 Discrimination by Metal Content and External Shape (Diameter)

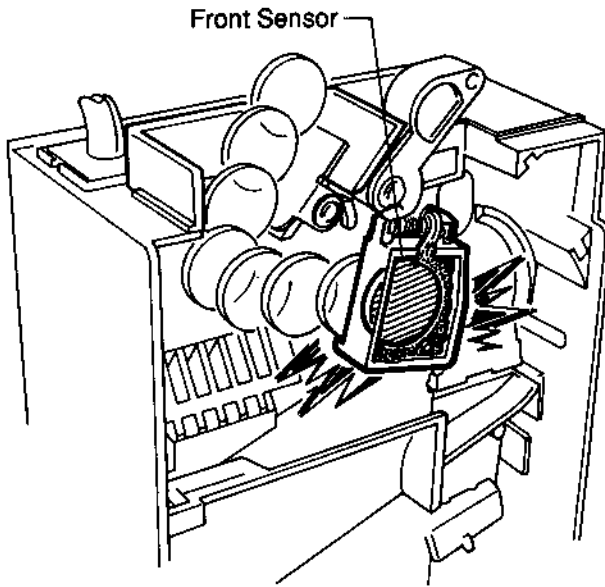

When coins pass between the front sensors, the metal content and diameter of the coins are checked and compared with the preset reference values of the control board. A coin is judged to be genuine only when these values match.

6-4-2 CREM Solenoid and CREM Extension

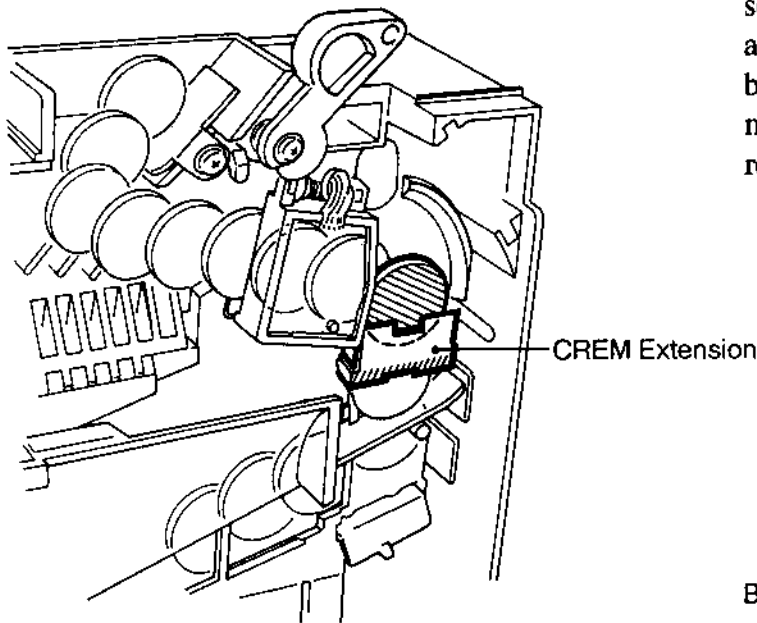

If a coin is judged to be good, the CREM solenoid operates, the CREM extension opens and the coin is received. If a coin is judged to be bad (defective), the CREM extension remains closed and the coin is guided to the return chute.

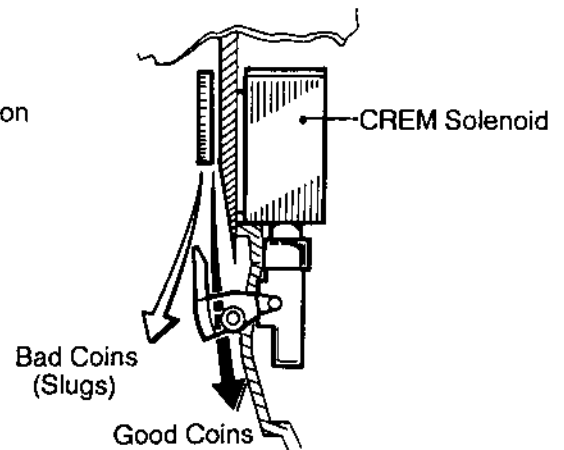

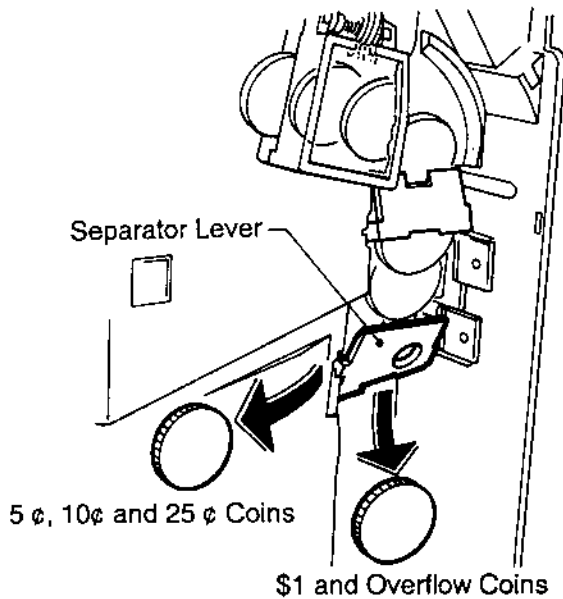
6. CONSTRUCTION AND DESCRIPTION**6-4-3 Separator Solenoid and Lever**

When 5¢, 10¢ and 25¢ coins are accepted, the separator solenoid operates and a chute rail guides the 5¢, 10¢ and 25¢ coins into their respective coin tubes. \$1 and overflow coins drop to the cash box.

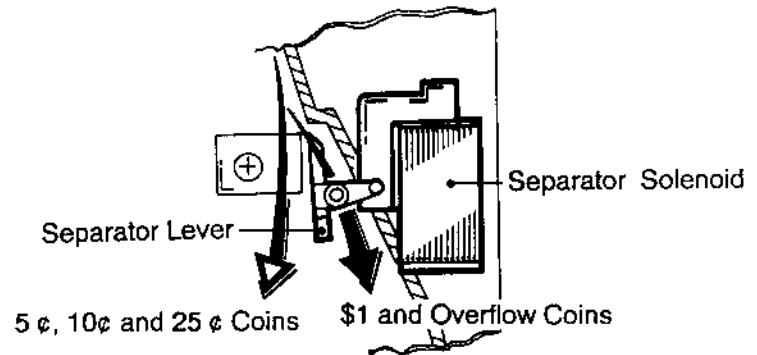
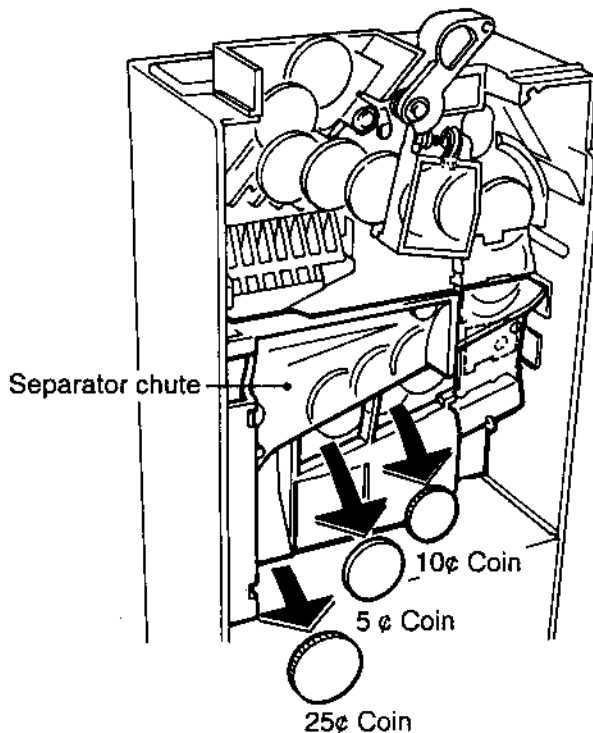
**6-4-4 Separation of 5¢, 10¢ and 25¢ coins by the Separator Chute**

25¢ coins roll along the rail in the separator chute and are guided to the 25¢ coin tube. 5¢ and 10¢ coins roll along the same rail in the separator chute but drop off along the way and are guided into their coin tubes.

6-5 Operation of Switches, Sensors, and Parts

6-5-1 Gate Lever Assembly and Related Parts

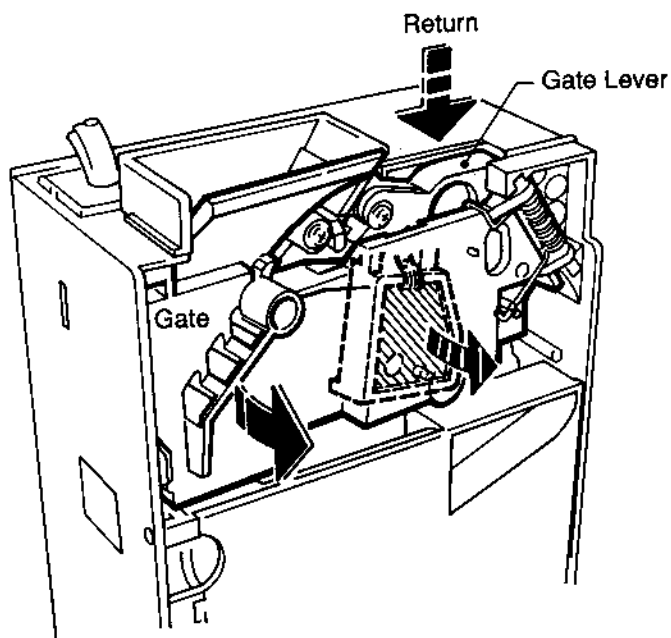

When the return lever on the vending machine is operated, it pushes the gate lever down and the gate opens.

If there are any defective coins, etc. stopped behind the gate, this operation causes them to be guided into the coin return chute. In addition, the movement of the front sensor causes the cancel signal to be sent. (escrow)

● The movement of the Front sensor

Normal Position Gate Lever Depressed

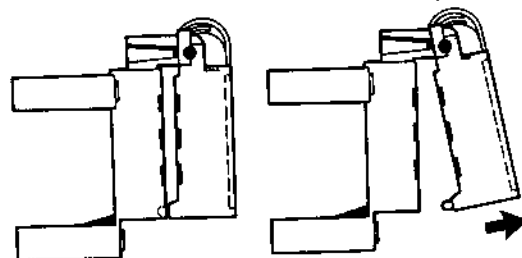

Cancel Signal OFF

Cancel Signal ON
(Escrow)

6-5-2 Anti Stringing Hook

The hook of the housing prevents stringing!

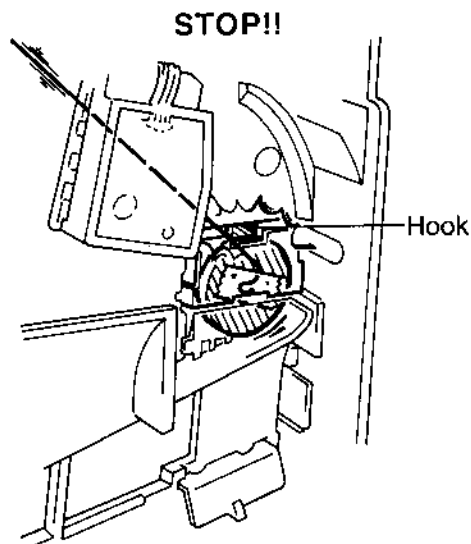
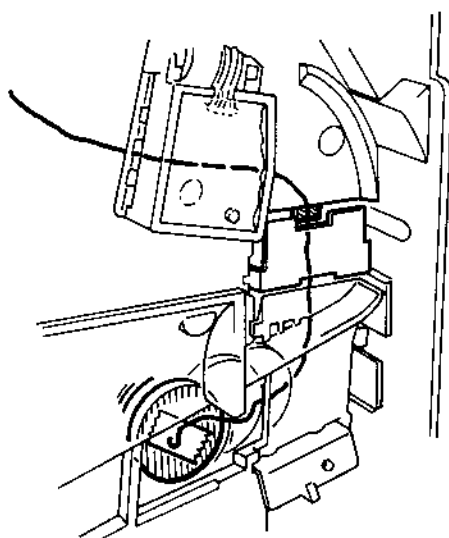

6. CONSTRUCTION AND DESCRIPTION

6-5-3 Credit Sensor

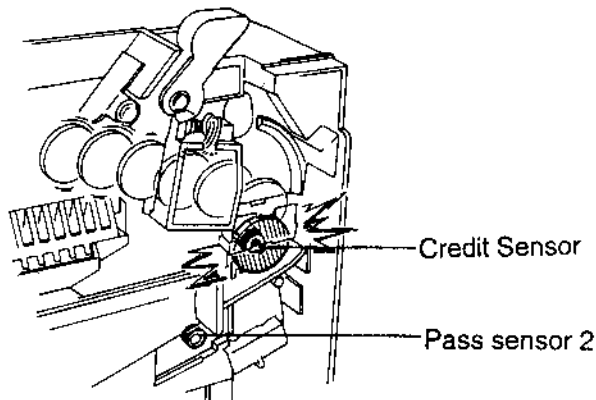

- Credit sensor
When a coin is determined to be genuine by the front sensor, it will be guided past the credit sensor and its value will be accumulated in the memory of the control board.

- Pass sensor
The pass sensor verifies coins routed to the tubes and reports to the controller.

6-5-4 Overflow and Empty Sensors

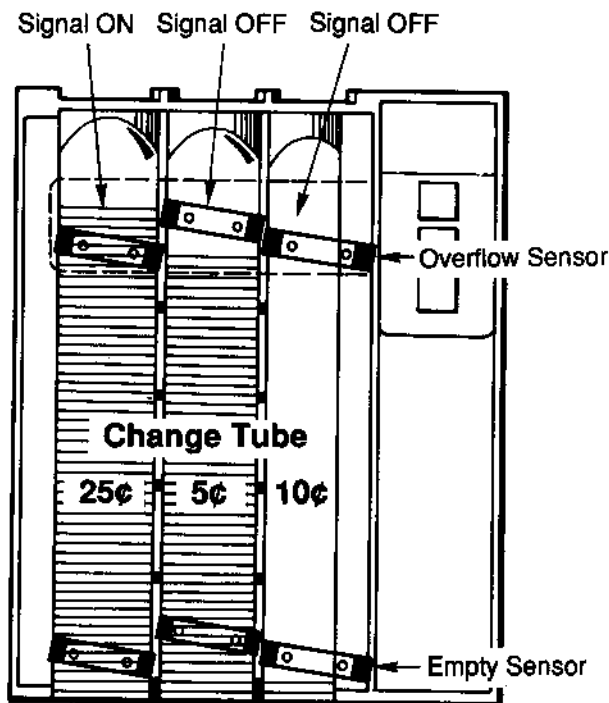

- Overflow sensor
This sensor detects the full level of coins in the change tube. If the tubes are full, the overflow signal is sent and coins are guided to the cash box.

- Empty sensor
This sensor detects the presence of coins in the change tube. The coin changer will determine the tubes to be empty when the coins are below the sensor levels.

5¢ coin change tube: 15 ± 3 coins
 10¢ coin change tube: 15 ± 3 coins
 25¢ coin change tube: 11 ± 3 coins

6-5-5 Inventory Switch

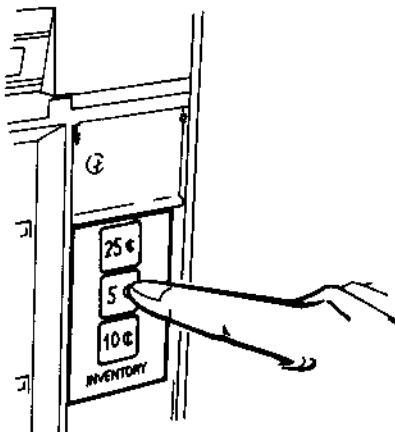

- Inventory switch
The inventory switch is used to empty the coin tubes, refer to page 7 for pay out.

6. CONSTRUCTION AND DESCRIPTION

6-6 Payout System

The 5-10-25¢ payout solenoids are operated by the control board.

When a solenoid is energized, the payout slide moves underneath the coin, which is paid out when power is removed from the solenoid.

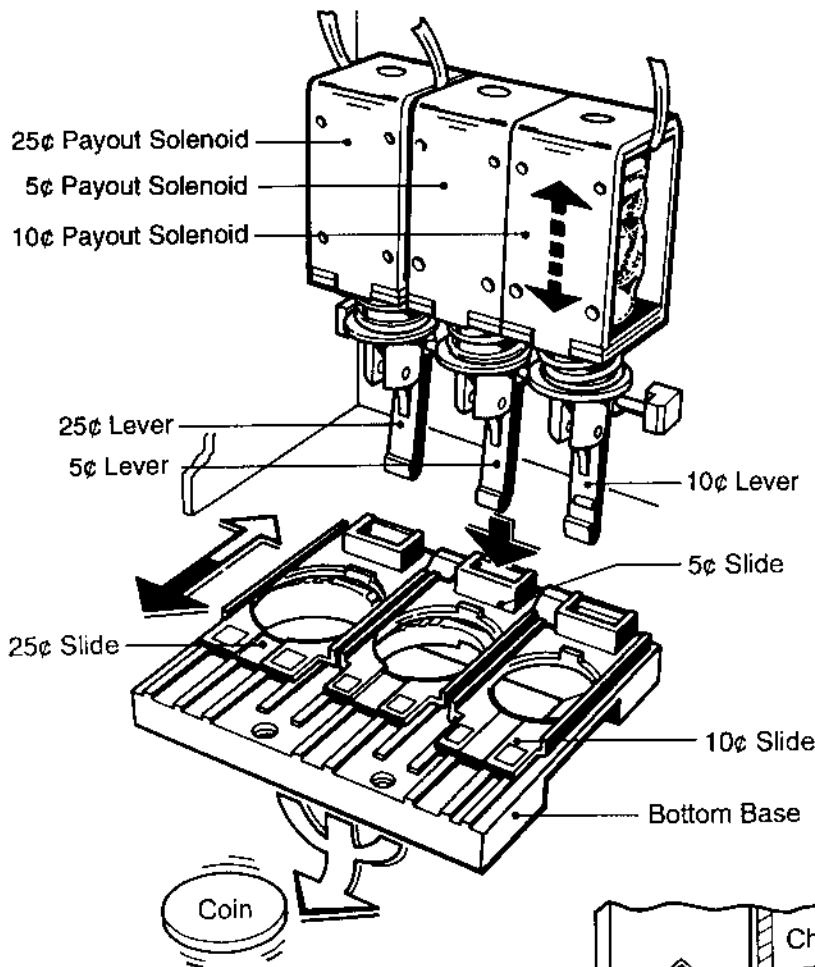

- 5¢ coin payout
Payout is made by the operation of the 5¢ payout solenoid.
- 10¢ coin payout
Payout is made by the operation of the 10¢ payout solenoid.
- 25¢ coin payout
Payout is made by the operation of the 25¢ payout solenoid.

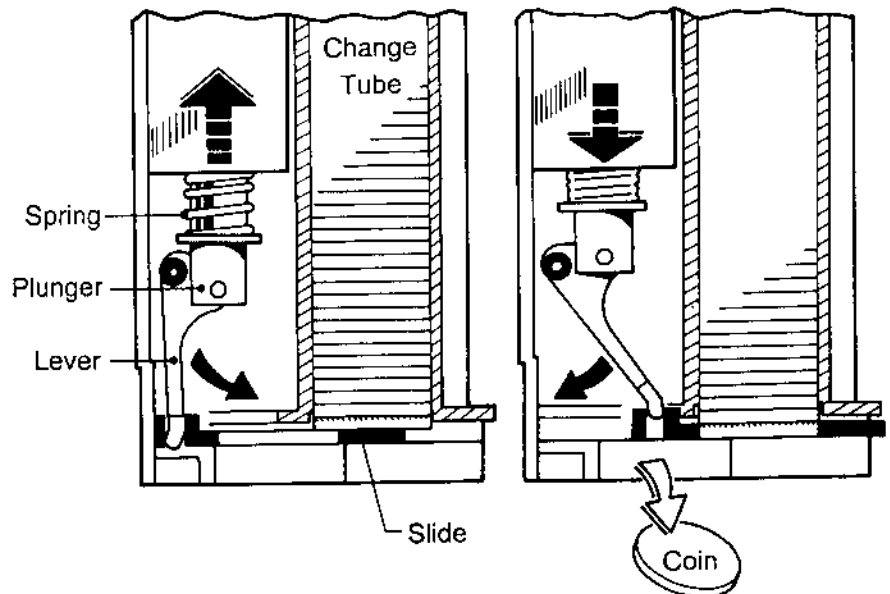

7. WIRING DIAGRAM

7-1 Connection Terminal Signal Conditions

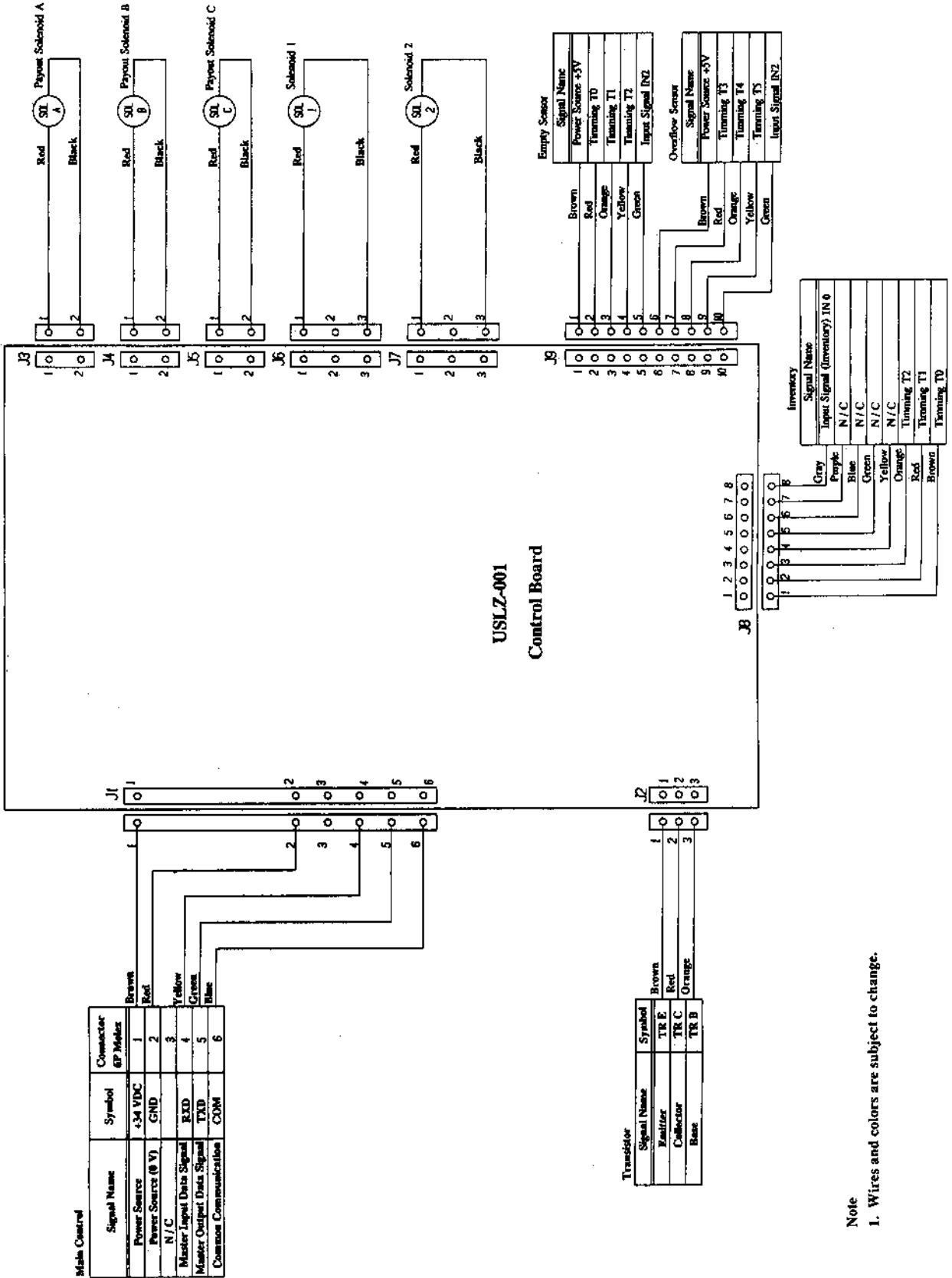

Note
1. Wires and colors are subject to change.

8. PREVENTIVE MAINTENANCE

The coin changer can become dirty from coins, dust, foreign matter, etc. and good coin acceptance cannot be maintained.

Use mild soap water to remove sticky matter, syrup, etc. **NEVER USE SOLVENTS!**

● Disassembly and assembly of chute cover and chute

- ① The chute cover can be removed by releasing the 2 locking tabs on the right side from the housing.

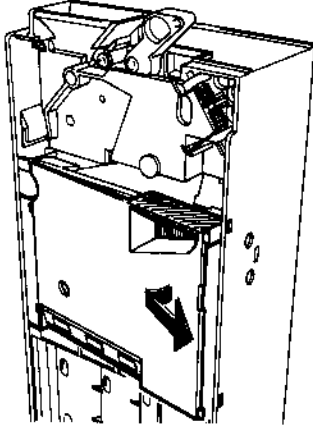

- ② The chute can be pulled out to the front after releasing the 2 locking tabs on the left side from the housing.

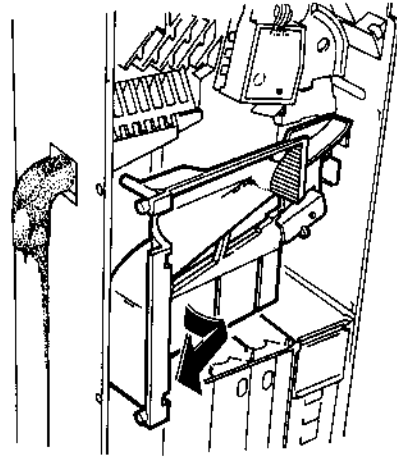

● Cleaning: Keep shaded area clean.

- ① Cleaning the gate
Open the gate assembly and use a dry cloth to remove any dirt from the coin path.

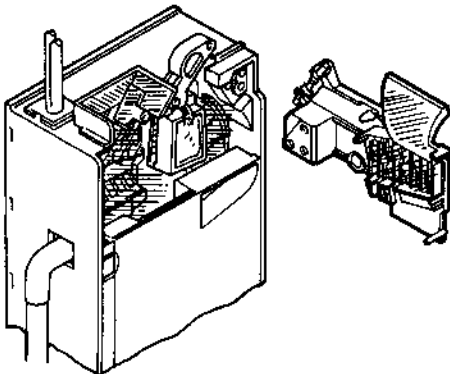

- ③ Cleaning of chute and housing
• Use a dry cloth to remove dirt from the coin path at the rear of the chute.

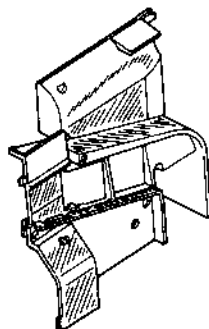

- ② Front sensor
Open the front sensor and use a soft cloth or a cotton swab to remove any dirt. The front sensor is a precision part of the coin changer, care is required when opening or closing the sensor ass'y.

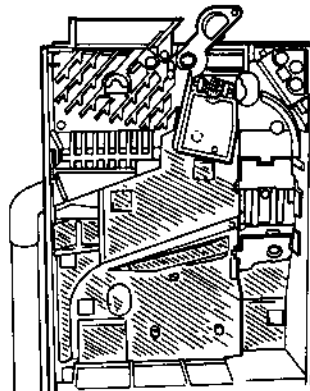
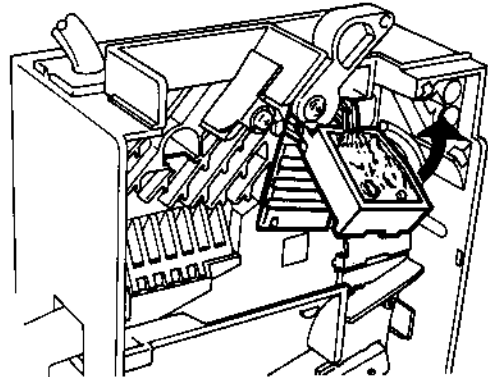

9. DISASSEMBLY AND ASSEMBLY PROCEDURE

Disassemble the coin changer in the order written, assemble in reverse order.

1. Removal of the Chute Cover .

Release the 2 locking tabs on the right side of the chute cover from the housing. Pull the chute cover out and to the right to remove.

- **Assembly Precautions:**

Insert the left side tabs of the chute cover into the chute first, then press the right side tabs into the housing.

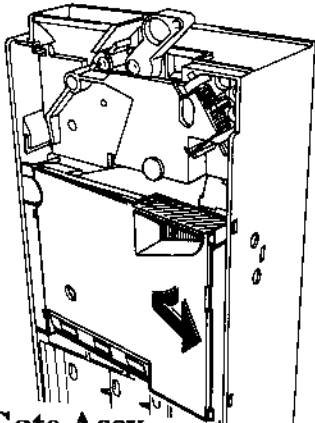
**2. Removal of The Chute**

Release the 2 locking tabs on the left side of the chute from the housing.

Pull the chute out and to the left to remove.

- **Assembly Precautions:**

Insert the right side tabs of the chute into the housing first, then press the left side tabs into the housing.

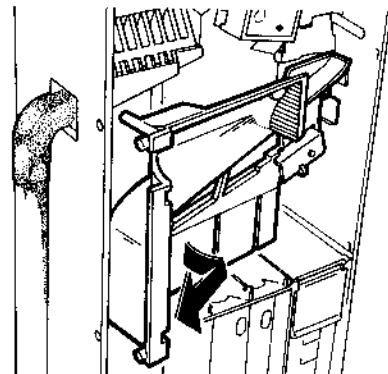
**3. Removal of The Gate Assy**

Release the gate spring by inserting a small screwdriver or scribe into the loop of the spring inside the housing, then pry the spring to the right and pull the gate out.

- **Assembly Precautions:**

When installing the gate, make sure the gate spring clips behind the housing.

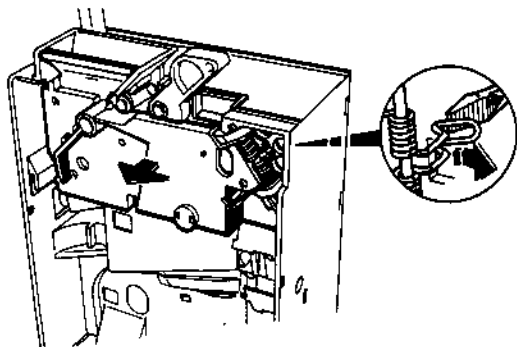
**4. Removal of The Drain Spout**

Lift up on the bottom of the drain spout and pull the left side out first.

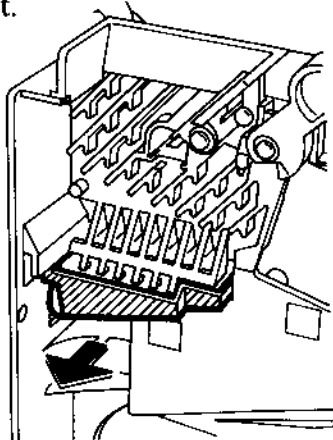
**5. Removal of The Back Cover**

Remove the 2 screws, pull the back cover out and to the right.

- **Assembly Precautions:**

Insert the left side tabs of the back cover into the side of the housing first.

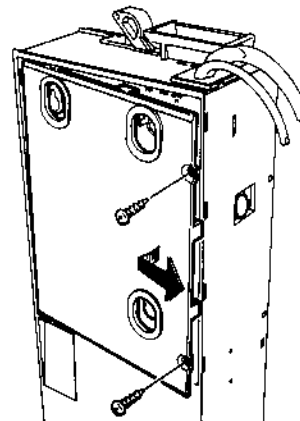

9. DISASSEMBLY AND ASSEMBLY PROCEDURE

6. Removal of The Control Board

Remove the 5 screws attaching the control board to the housing. Gently push the front sensor through the housing and unplug the connectors.

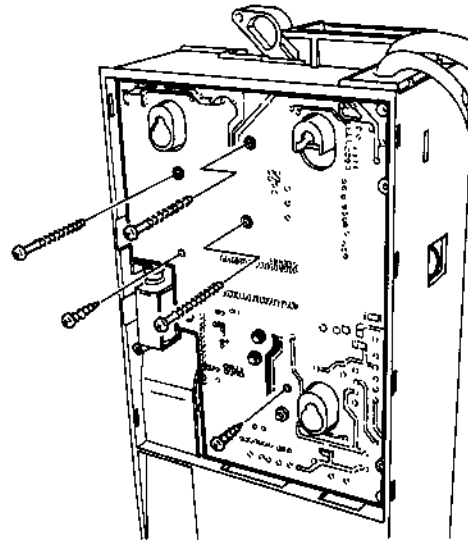

7. Removal of The Change Tube Assy.

Release the locking tabs on the left and right sides of the change tube assy from the housing, then pull out and up to remove.

- **Assembly Precautions:**

First, feed the wires through the housing, to the back side. Next insert the bottom of the change tube assy into the bottom of the housing, then the top.

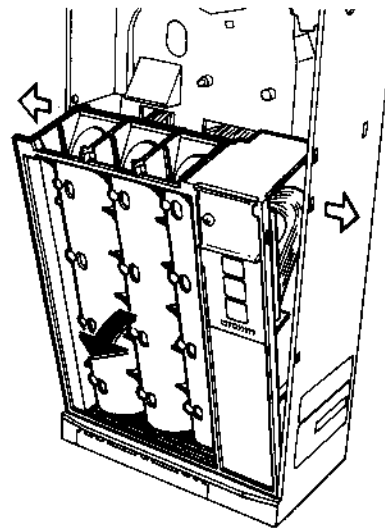

① Removal of The Heatsink Assy

Remove the 2 screws attaching the heatsink Assy to the change tubes.

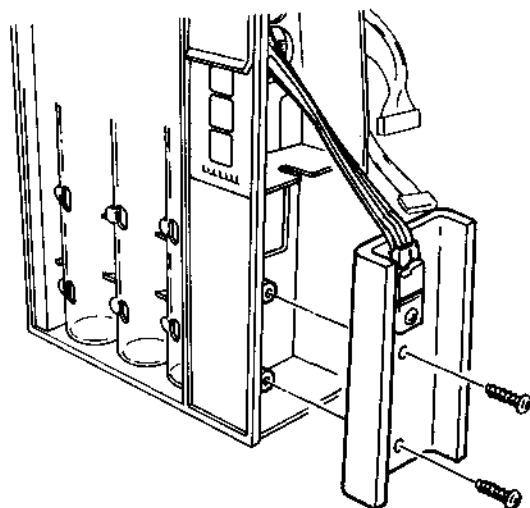

② Removal of The Inventory Board Assy

Remove the 2 screws attaching the inventory board to the change tubes.

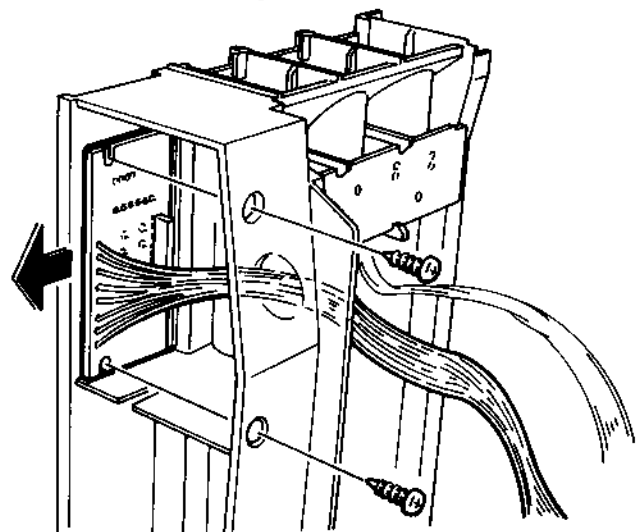

Continues on next page →

9. DISASSEMBLY AND ASSEMBLY PROCEDURE**③ Removal of The Sensor Board Assy**

Cut the cable tie attaching the wires to the latch.

Spread the latches apart to remove the sensor board assy.

- **Assembly Precautions:**

Be careful not to damage the L.E.D. sensors when installing.

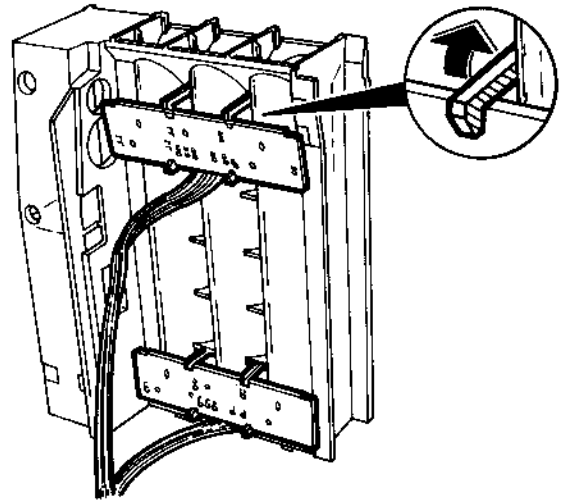
**8. Removal of The Bottom Base and 5¢, 10¢, and 25¢ Slides**

Remove the 2 screws attaching the bottom base to the housing, then remove the 5¢, 10¢, and 25¢ slides

- **Assembly Precautions:**

Insert the tabs of the bottom base into the back side of the housing, then the screws.

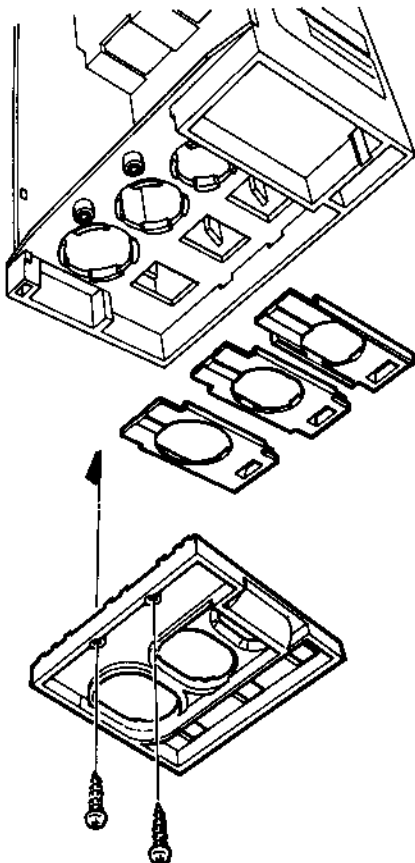
**9. Removal of The Payout Solenoids**

Remove the 2 screws attaching each solenoid to the housing.

- **Assembly Precautions:**

Install the payout solenoids in the correct locations:

1 = 25¢ (White connector),

2 = 5¢ (Blue connector),

3 = 10¢ (Black connector).

Route the wires as shown.

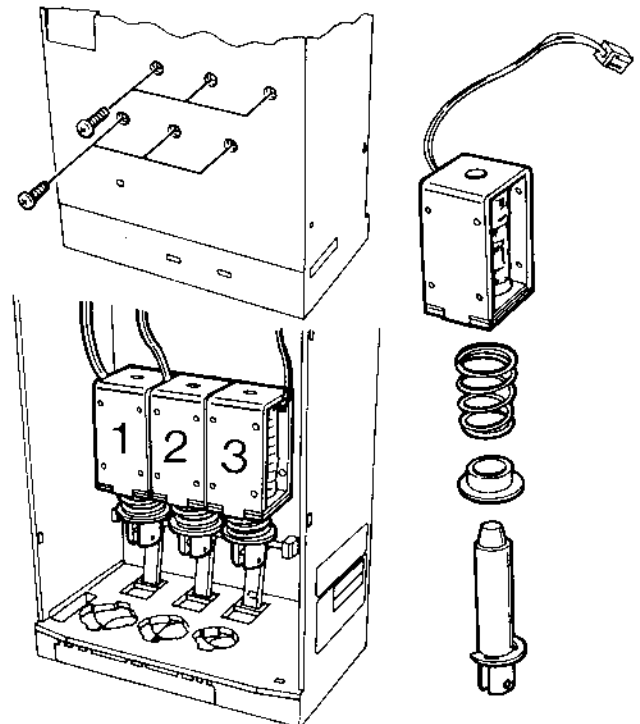

10. Removal of Levers (A), (B) and The Lever Shaft

Remove the retaining ring from the left side of the lever shaft, then slide it out of the housing.

- Assembly Precautions:
Lever (B) must be installed in the 10¢ slot.

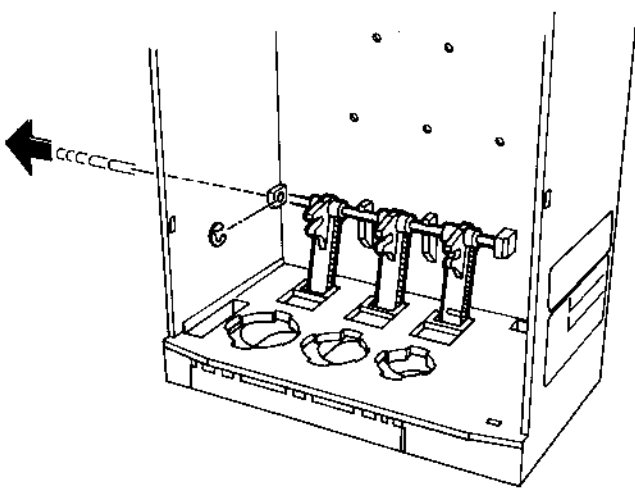

11. Removal of The Funnel Guide and Funnel

Remove the screw attaching the funnel guide, then remove the screw attaching the funnel to the housing.

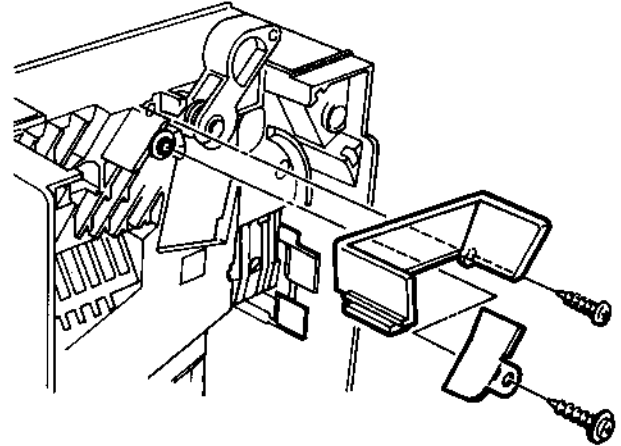

12. Removal of The Gate Lever and Spring

Remove the screw attaching the gate lever to the housing, then release the lever spring from the housing with a small screwdriver.

- Assembly Precautions:
Insert the spring into the gate lever before assembling.

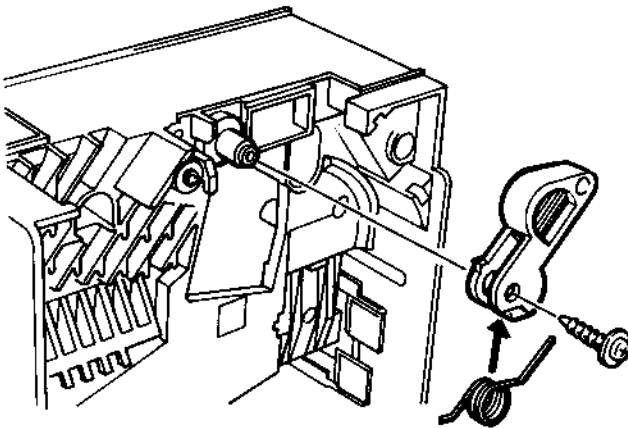

13. Removal of The CREM and Separator Solenoids

Remove the screws on the front side of the housing that attach the CREM and separator solenoids.

- Assembly Precautions:
Make sure that the solenoid arm engages the lever for correct operation.

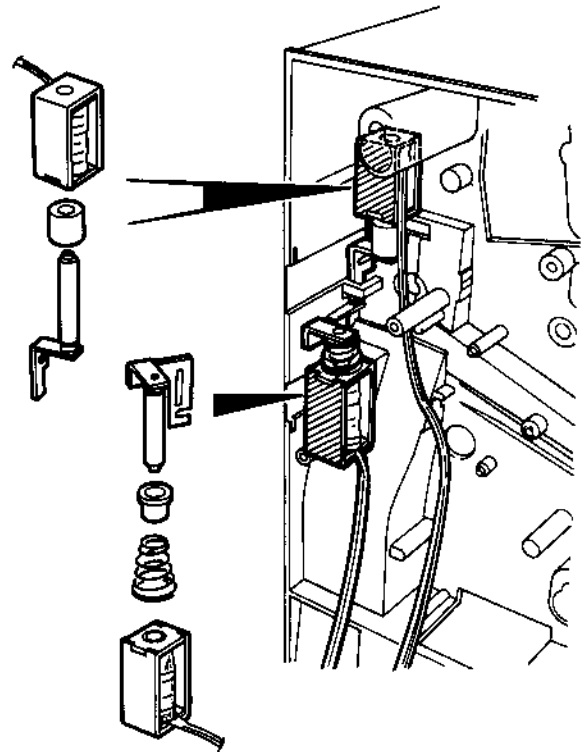

13-1. Removal of The CREM Extension and Separator Lever

Release the tab on the right side from the housing first, then remove.

- Assembly Precautions:
Insert the left side tab first, then push the right side in place.

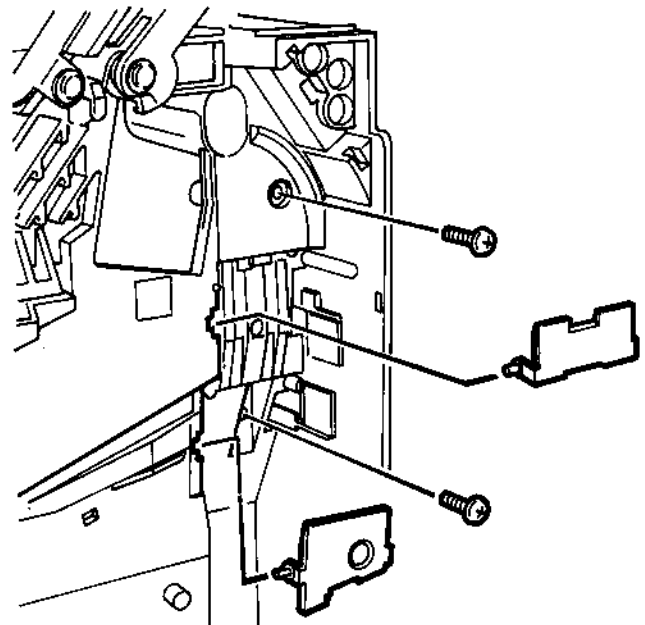

9. DISASSEMBLY AND ASSEMBLY PROCEDURE

14. Removal of The Power Supply Harness Assy

Remove the screw attaching the harness guide to the housing, then remove the harness guide from the side of the housing. Pull the power supply harness assy and bushing from the top of the housing.

- **Assembly Precautions:**
Make sure the harness bushing is seated properly in the top of the housing.

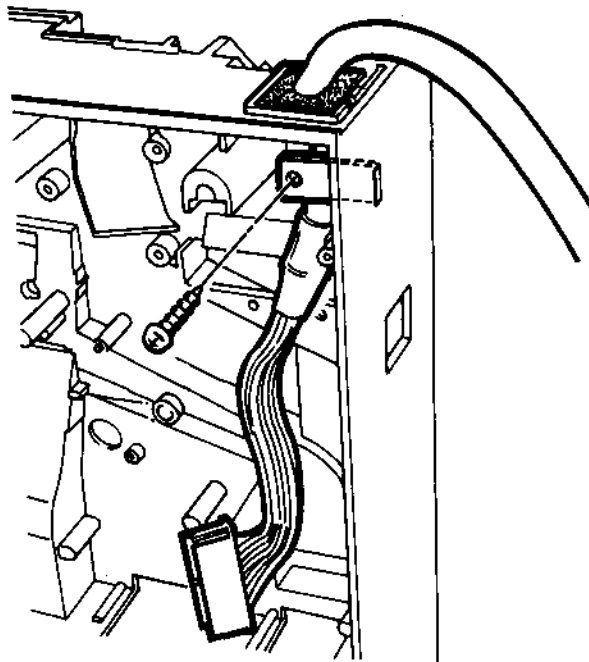

10. PARTS DIAGRAM AND PARTS LIST

10. PARTS DIAGRAM AND PARTS LIST

10-1 Changer (Front Side)

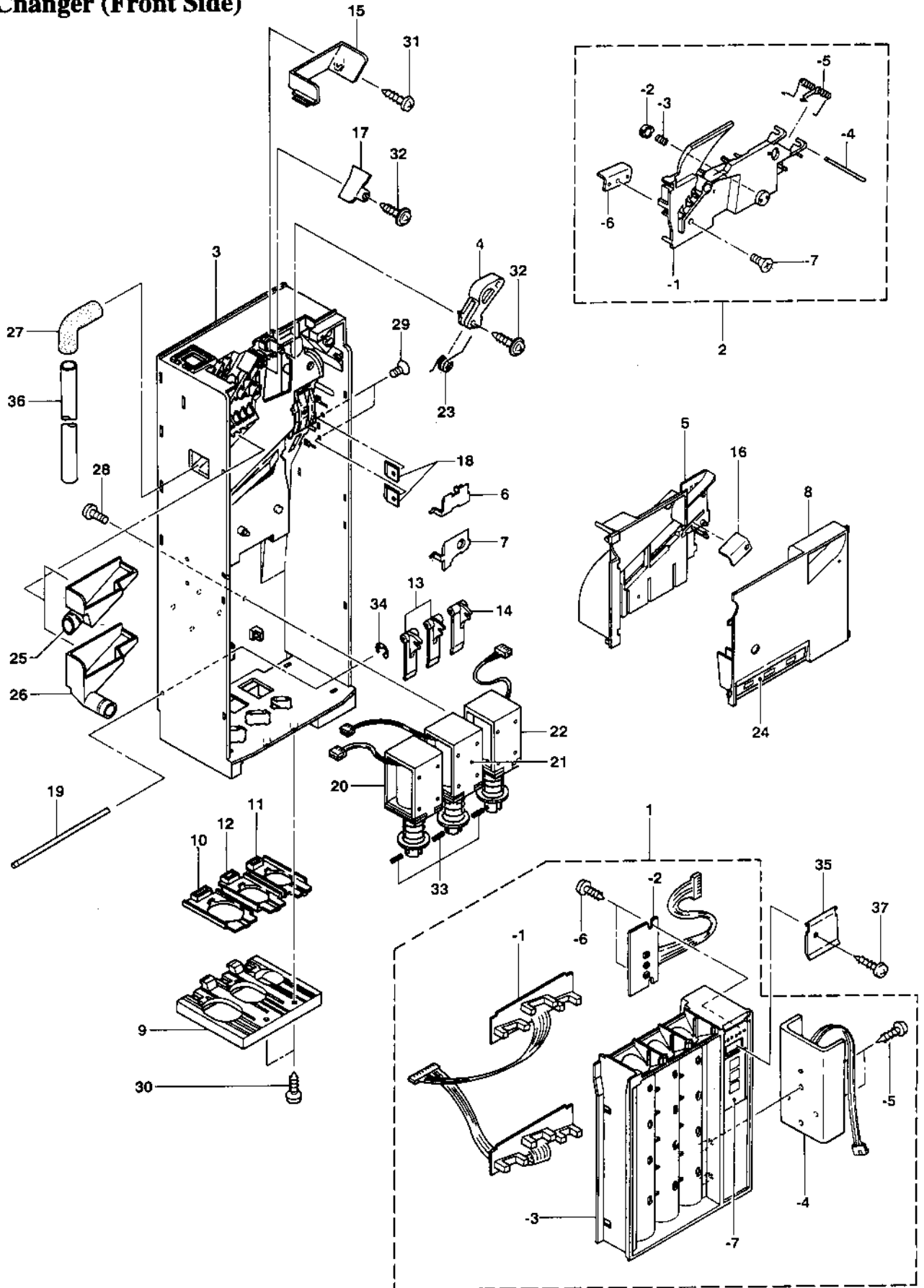

10. PARTS DIAGRAM AND PARTS LIST

USLZ-1
SERIES

25

INDEX NO.	PART NO.	DESCRIPTION	QTY	REMARKS
1		Change Tube (2) ASSY		
1-1	252203	Sensor Board ASSY	1	
1-2	252222	Inventory Board ASSY	1	
1-3	252413	Change Tube	1	
1-4	252109	Heatsink ASSY	1	
1-5	904028	Self Tapping Screw	2	(+)Pan-head M3 × 8
1-6	904027	Self Tapping Screw	2	(+)Pan-head M3 × 6
1-7	252511	Inventory Seal (A)	1	
2		Gate ASSY		
2-1	252402	Gate	1	
2-2	252424	Coil Case Cap	1	
2-3	367509	Cap Spring	1	
2-4	361503	Gate Pin	1	
2-5	252505	Gate Spring	1	
2-6	252502	Gate Rail	1	
2-7	902003	Screw	1	(+)Flat-head M3 × 4
3	252432	Housing	1	
4	252431	Gate Lever (2)	1	
5	252406	Chute	1	
6	252407	CREM Extension	1	
7	252408	Separator Lever	1	
8	252412	Chute Cover	1	
9	252433	Bottom Base	1	
10	252434	25¢ Slide	1	
11	252435	10¢ Slide	1	
12	252436	5¢ Slide	1	
13	252418	Lever (A)	2	
14	252419	Lever (B)	1	
15	252422	Funnel	1	
16	252501	Chute Rail	1	
17	252503	Funnel Guide	1	
18	361510	Route Plate	2	
19	252504	Lever Shaft	1	
20	252733	Payout Solenoid (4)	1	25¢ (White Connector)
21	252734	Payout Solenoid (5)	1	5¢ (Blue Connector)
22	252735	Payout Solenoid (6)	1	10¢ (Black Connector)
23	362505	Gate Lever Spring	1	
24	252512	Tube Seal	1	
25	252420	Drain Spout	1	Side Type
26	252426	Drain Spout(2)	1	Front Type
27	252428	Rubber Elbow	1	Front & Side Type
28	900008	Screw	6	(+)Pan-head M3 × 6
29	902003	Screw	2	(+)Flat-head M3 × 4
30	904211	Self Tapping Screw	2	(+)Pan-head M3 × 10
31	904209	Self Tapping Screw	1	(+)Pan-head M3 × 8
32	904804	Self Tapping Screw with Washer	2	(+)Pan-head M3 × 6
33	907927	Spring Pin	3	∅ 3 × 12
34	332509	Retaining Ring	1	∅ 1.9
35	252427	Price Switch Cover	1	
36	252526	Drain Tube	1	1ft.
37		Self Tapping Screw	1	

10. PARTS DIAGRAM AND PARTS LIST

10-2 Changer(Rear Side)

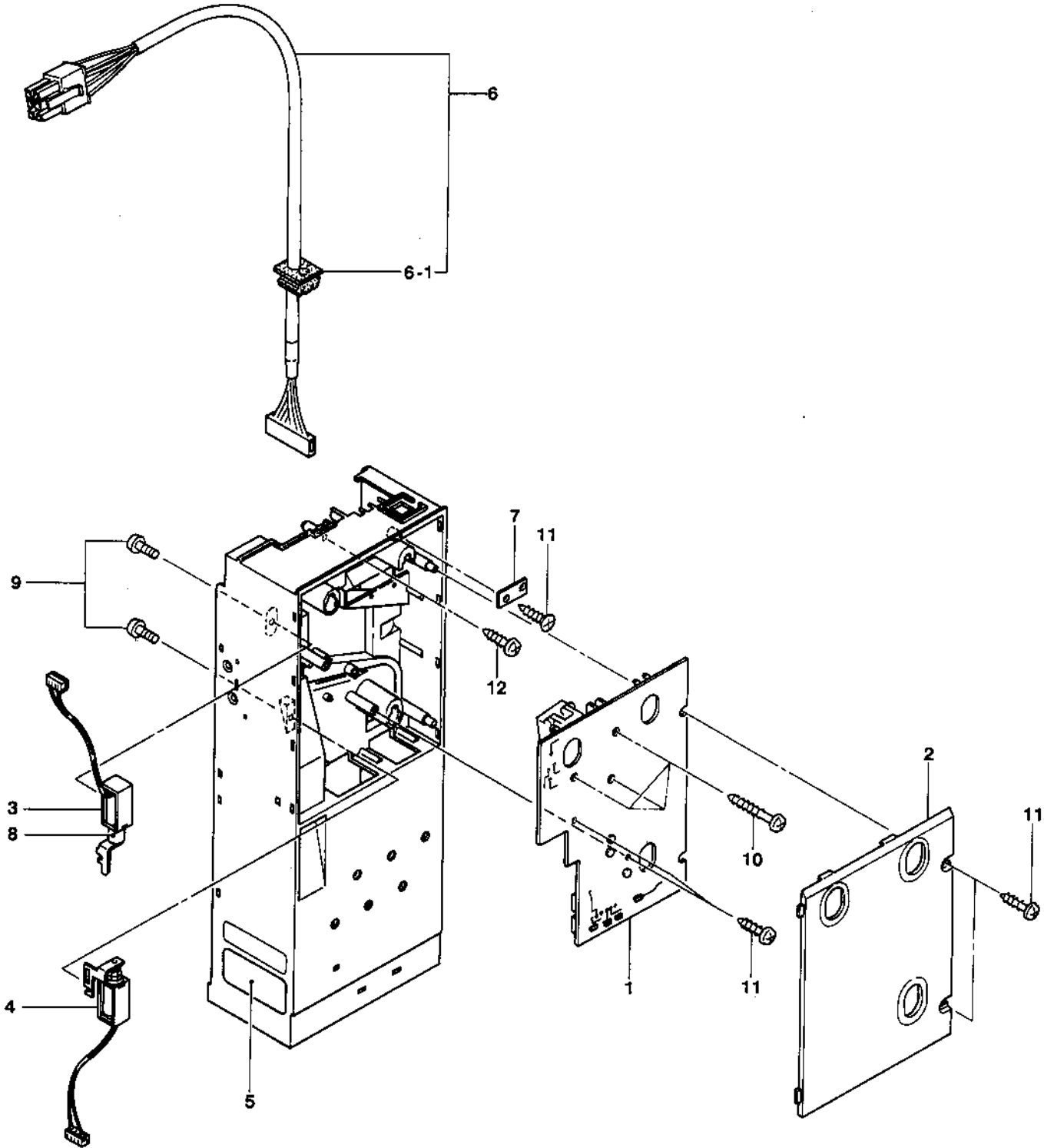

10. PARTS DIAGRAM AND PARTS LIST

USLZ-1
SERIES

27

INDEX NO.	PART NO.	DESCRIPTION	QTY	REMARKS
1	252220	Control Board ASSY	1	
2	252421	Back Cover	1	
3	252736	CREM Solenoid (3)	1	
4	252737	Separator Solenoid (4)	1	
5	252528	Machine Nameplate (2)	1	
6	252341	Power Supply Harness ASSY	1	
6-1	252507	Rubber Bushing	1	
7	252524	Harness Guide	1	
8	252520	Solenoid Collar	1	
9	900006	Screw	2	(+)Pan-head M3 × 4
10	904214	Self Tapping Screw	3	(+)Pan-head M3 × 30
11	904209	Self Tapping Screw	5	(+)Pan-head M3 × 8
12	904208	Self Tapping Screw	1	(+)Pan-head M3 × 6

11. EXTERNAL VIEW AND DIMENSIONS

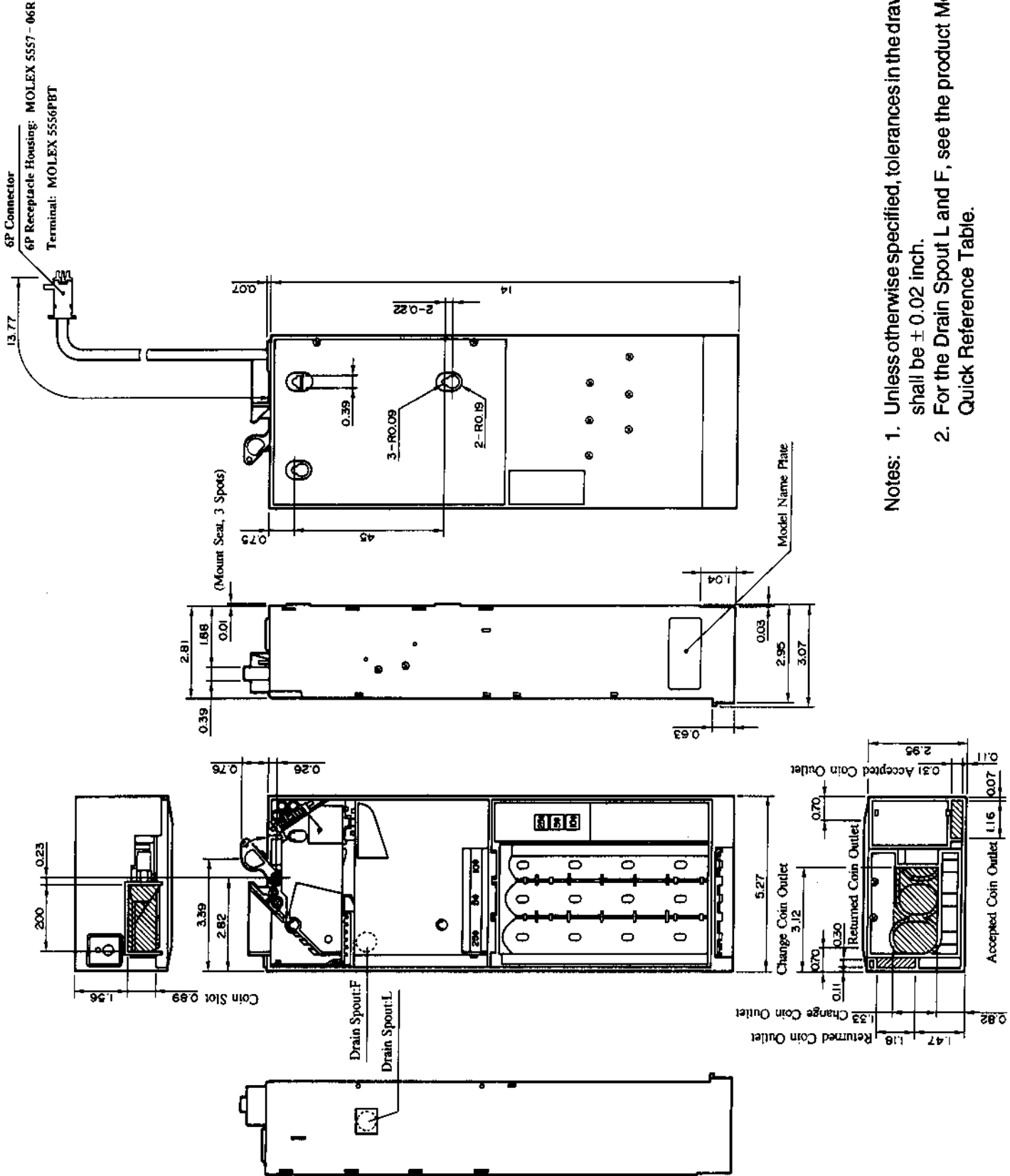

- Notes: 1. Unless otherwise specified, tolerances in the drawing shall be ± 0.02 inch.
2. For the Drain Spout L and F, see the product Model Quick Reference Table.